

# GUARDIAN

## *A6-12000 IP Dispensing System*

**For use with non-flammable foam and polyurea.  
Not for use in explosive atmospheres.**

**Maximum fluid working pressure:  
(2200 psi. (15.2 MPa, 152 bar)**



**Important Safety Instructions**

Read all warnings and instructions in this manual. Save these instructions.



USER MANUAL

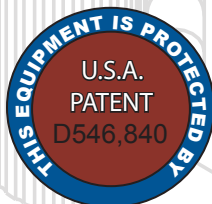

# Table Of Contents

## Section 1 Installation

Warnings ..... 1  
Standard Equipment..... 5  
Specifications..... 6  
Introduction..... 7  
Equipment Assembly ..... 9

## Section 2 Operation

Start-up Instructions ..... 15  
Shut-down Instructions ..... 20

## Section 3 General Information





Assembly Drawings ..... 24  
Sub Assembly Drawings ..... 30  
Maintenance ..... 36  
Troubleshooting ..... 37  
Options ..... 40

## Section 4 Safety Information

Notes ..... 41  
Limited Warranty Policy ..... 43  
Technical Assistance ..... 44  
For Your Reference ..... **INSIDE BACK COVER**





# Warnings

The following warnings are for the setup, use, grounding, maintenance, and repair of this equipment. The exclamation point symbol alerts you to a general warning and the hazard symbol refers to procedure-specific risk. Refer back to these warnings. Additional, product-specific warnings may be found throughout the body of this manual where applicable.

 <b>WARNING</b>	
	<p><b>ELECTRIC SHOCK HAZARD</b> Improper grounding, setup, or usage of the system can cause electric shock.</p> <ul style="list-style-type: none"> <li>• Turn off and disconnect power cord before servicing equipment.</li> <li>• Use only grounded electrical outlets.</li> <li>• Use only 3-wire extension cords.</li> <li>• Ensure ground prongs are intact on sprayer and extension cords.</li> <li>• Do not expose to rain. Store indoors.</li> </ul>
	<p><b>TOXIC FLUID OR FUMES HAZARD</b> Toxic fluids or fumes can cause serious injury or death if splashed in the eyes or on skin, inhaled, or swallowed.</p> <ul style="list-style-type: none"> <li>• Read MSDS's to know the specific hazards of the fluids you are using.</li> <li>• Store hazardous fluid in approved containers, and dispose of it according to applicable guidelines.</li> <li>• Always wear impervious gloves when spraying or cleaning equipment.</li> </ul>
	<p><b>PERSONAL PROTECTIVE EQUIPMENT</b> You must wear appropriate protective equipment when operating, servicing, or when in the operating area of the equipment to help protect you from serious injury, including eye injury, inhalation of toxic fumes, burns, and hearing loss. This equipment includes but is not limited to:</p> <ul style="list-style-type: none"> <li>• Protective eyewear</li> <li>• Clothing and respirator as recommended by the fluid and solvent manufacturer</li> <li>• Gloves</li> <li>• Hearing protection</li> </ul>
	<p><b>SKIN INJECTION HAZARD</b> High-pressure fluid from gun, hose leaks, or ruptured components will pierce skin. This may look like just a cut, but it is a serious injury that can result in amputation. <b>Get immediate surgical treatment.</b></p> <ul style="list-style-type: none"> <li>• Do not point gun at anyone or at any part of the body.</li> <li>• Do not put your hand over the spray tip.</li> <li>• Do not stop or deflect leaks with your hand, body, glove, or rag.</li> <li>• Close material shutoff valves and shutoff or disconnect air supply when not spraying.</li> <li>• Follow <b>Pressure Relief Procedure</b> in this manual, when you stop spraying and before cleaning, checking, or servicing equipment.</li> </ul>

## Warnings

### ! WARNING

	<p><b>FIRE AND EXPLOSION HAZARD</b></p> <p>Flammable fumes, such as solvent and paint fumes, in work area can ignite or explode. To help prevent fire and explosion:</p> <ul style="list-style-type: none"> <li>• Use equipment only in well ventilated area.</li> <li>• Eliminate all ignition sources; such as pilot lights, cigarettes, portable electric lamps, and plastic drop cloths (potential static arc).</li> <li>• Keep work area free of debris, including solvent, rags and gasoline.</li> <li>• Do not plug or unplug power cords, or turn power or light switches on or off when flammable fumes are present.</li> <li>• Ground all equipment in the work area.</li> <li>• Use only grounded hoses.</li> <li>• Hold gun firmly to side of grounded pail when triggering into pail.</li> <li>• If there is static sparking or you feel a shock, <b>stop operation immediately</b>. Do not use equipment until you identify and correct the problem.</li> <li>• Keep a working fire extinguisher in the work area.</li> </ul>
	<p><b>PRESSURIZED ALUMINUM PARTS HAZARD</b></p> <p>Do not use 1,1,1-trichloroethane, methylene chloride, other halogenated hydrocarbon solvents or fluids containing such solvents in pressurized aluminum equipment. Such use can cause serious chemical reaction and equipment rupture, and result in death, serious injury, and property damage.</p>
	<p><b>EQUIPMENT MISUSE HAZARD</b></p> <p>Misuse can cause death or serious injury.</p> <ul style="list-style-type: none"> <li>• Do not operate the unit when fatigued or under the influence of drugs or alcohol.</li> <li>• Do not exceed the maximum working pressure or temperature rating of the lowest rated system component. See <b>Technical Data</b> in all equipment manuals.</li> <li>• Use fluids and solvents that are compatible with equipment wetted parts. See <b>Technical Data</b> in all equipment manuals. Read fluid and solvent manufacturer's warnings. For complete information about your material, request MSDS forms from distributor or retailer.</li> <li>• Check equipment daily. Repair or replace worn or damaged parts immediately with genuine manufacturer's replacement parts only.</li> <li>• Do not alter or modify equipment.</li> <li>• Use equipment only for its intended purpose. Call your distributor for information.</li> <li>• Route hoses and cables away from traffic areas, sharp edges, moving parts, and hot surfaces.</li> <li>• Do not kink or over bend hoses or use hoses to pull equipment.</li> <li>• Keep children and animals away from work area.</li> <li>• Comply with all applicable safety regulations.</li> </ul>
	<p><b>MOVING PARTS HAZARD</b></p> <p>Moving parts can pinch or amputate fingers and other body parts.</p> <ul style="list-style-type: none"> <li>• Keep clear of moving parts.</li> <li>• Do not operate equipment with protective guards or covers removed.</li> <li>• Pressurized equipment can start without warning. Before checking, moving, or servicing equipment, follow the <b>Pressure Relief Procedure</b> in this manual. Disconnect power or air supply.</li> </ul>
	<p><b>BURN HAZARD</b></p> <p>Equipment surfaces and fluid that's heated can become very hot during operation. To avoid severe burns, do not touch hot fluid or equipment. Wait until equipment/fluid has cooled completely.</p>

## Warnings



### Isocyanate Hazard

					
<p>Spraying materials containing isocyanates creates potentially harmful mists, vapors, and atomized particulates.</p> <p>Read material manufacturer's warnings and material MSDS to know specific hazards and precautions related to isocyanates.</p> <p>Prevent inhalation of isocyanate mists, vapors, and atomized particulates by providing sufficient ventilation in the work area. If sufficient ventilation is not available, a supplied-air respirator is required for everyone in the work area.</p> <p>To prevent contact with isocyanates, appropriate personal protective equipment, including chemically impermeable gloves, boots, aprons, and goggles, is also required for everyone in the work area.</p>					

To prevent exposing ISO to moisture:

- Always use a sealed container with a desiccant dryer in the vent, or a nitrogen atmosphere. **Never** store ISO in an open container.
- Keep the ISO lube pump reservoir filled with Graco Throat Seal Liquid (TSL), Part 206995. The lubricant creates a barrier between the ISO and the atmosphere.
- Use moisture-proof hoses specifically designed for ISO, such as those supplied with your system.
- Never use reclaimed solvents, which may contain moisture. Always keep solvent containers closed when not in use.
- Never use solvent on one side if it has been contaminated from the other side.
- Always park pumps when you shutdown.
- Always lubricate threaded parts with Part 217374 ISO pump oil or grease when reassembling.

### Material Self-Ignition

					
<p>Some materials may become self-igniting if applied too thickly. Read material manufacturer's warnings and material MSDS.</p>					

### Moisture Sensitivity of Isocyanates

Isocyanates (ISO) are catalysts used in two component foam and polyurea coatings. ISO will react with moisture (such as humidity) to form small, hard, abrasive crystals, which become suspended in the fluid. Eventually a film will form on the surface and the ISO will begin to gel, increasing in viscosity. If used, this partially cured ISO will reduce performance and the life of all wetted parts.



The amount of film formation and rate of crystallization varies depending on the blend of ISO, the humidity, and the temperature.

## Warnings

### Keep Components A and B Separate

#### CAUTION

To prevent cross-contamination of the equipment's wetted parts, never interchange component A (isocyanate) and component B (resin) parts. The gun is shipped with the A side on the left. The fluid manifold, fluid housing, side seal assembly, check valve cartridge, and mix chamber are marked on the A side.

### Foam Resins with 245 fa Blowing Agents

New foam blowing agents will froth at temperatures above 90°F (33 °C) when not under pressure, especially if agitated. To reduce frothing, minimize preheating in a circulation system.

### Changing Materials

- When changing materials, flush the equipment multiple times to ensure it is thoroughly clean.
- Always clean the fluid inlet strainers after flushing.
- Check with your material manufacturer for chemical compatibility.
- Most materials use ISO on the A side, but some use ISO on the B side.
- Epoxies often have amines on the B (hardener) side. Polyureas often have amines on the B (resin) side.

## Section 1 - Installation: Standard Equipment

### Model - A6-12000 IP

<b>Part Number</b>	<b>Description</b>
GC1826	A6-12000 IP UNIT, 220V, 1PH, F
GC1828	A6-12000 IP UNIT, 220V, 3PH, F
GCP2R1	PROBLER P2 GUN
GC0393	48 FT. HEATED HOSE ASSEMBLY
313275	USER MANUAL
206995	FLUID, TSL, 1 QT. BOTTLE
GC0174	TRANSFER KIT, A5 AND A6 (DOES NOT INCLUDE TRANSFER PUMPS)

\* Purchased separately.

### Recommended Repair Parts

<b>Part Number</b>	<b>Description</b>
GC1748	HEATER REPAIR KIT

### Related Manuals

<b>Part Number</b>	<b>Description</b>
312766	T1 2:1 RATIO TRANSFER PUMP MANUAL
313277	MATERIAL PUMPS MANUAL

## Section 4 - Installation: Specifications

Material Ratio:	1:1 (Fixed)
Material Viscosity:	200- 2000 Centipoise (Cps) @ AMBIENT
Output:	Pumps Rated: .042 Gallons Per Cycle .159 Liters Per Cycle
Operating Temperatures:	32° F ( 0° C ) - 180° ( 82 ° C )
Maximum Air Working Pressure	100 psi (0.69 MPa, 6.9 bar)
Maximum Fluid Working Pressure:	22:1 RATIO 2200 psi (15.2 MPa, 152 bar)
Electrical Requirements:	75 A @ 208/240 VAC,50/60 hz, Single Phase (cable: 2 AWG, 2 wire + GND) 40 A @ 208/240 VAC,50/60 hz. Three Phase (cable: 8 AWG, 3 wire + GND)
Compressed Air Requirements:	Base Unit: 1.0 GAL PER MINUTE – 32 CFM @ 100 PSI. <b>NOTE:</b> As output is increased, (achieved w/ chamber size on gun or spray tip), pressure drop will be greater. Heating capability will also drop.
Heaters:	12000 WATT HEATER
Maximum Hose Length:	200 ft (61 m) (Each Section 50 ft. x 3/8 in. I.D.)
Shipping Weight:	428 lbs. (194 kg)
Overall Dimensions:	

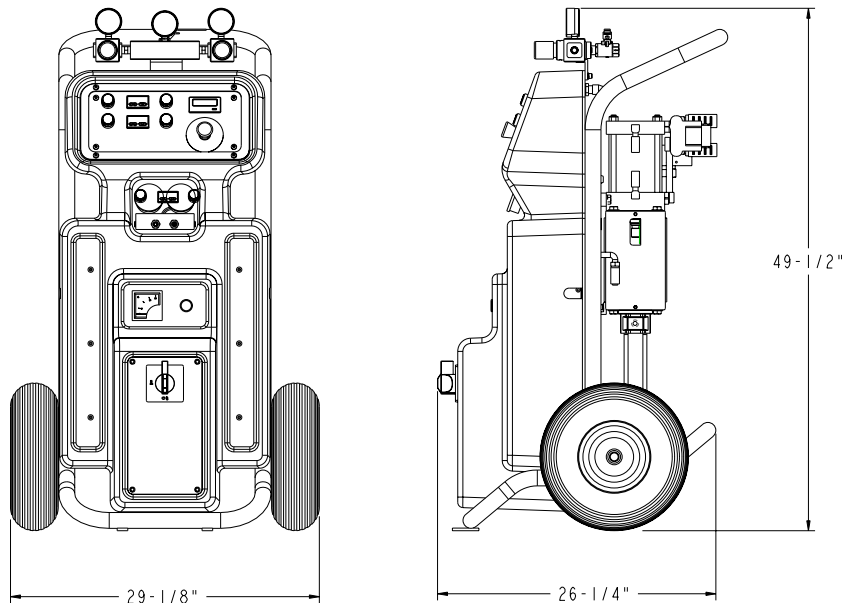



## Section 1 - Installation: Introduction

Before operating, maintaining or servicing any **GlasCraft** system, read and understand all of the technical and safety literature provided with **GlasCraft** products. If you do not have the proper or related manuals and safety literature for your **GlasCraft** system, contact your **GlasCraft** distributor.

In this **GlasCraft** technical and safety publication, the following advisories will be provided where appropriate:



Information about the procedure in progress.



*Is imperative information about equipment protection.*



*Indicates a hazardous situation that can result in minor or moderate injury.*



*Indicates a hazardous situation that can result in death or serious injury.*



*Indicates a hazardous situation that can result in electrical shock or serious injury.*

The information in this document is intended only to indicate the components and their normal working relationship typical use. Each assembly should be directed by a **GlasCraft** distributor or made from the **GlasCraft** Assembly instructions provided.

This manual provides information for the assembly, operation, maintenance and service of this **GlasCraft** product as used in a typical configuration. While it lists standard specifications and procedures, some deviations may be found.

In order to provide our users with the most up-to-date technology possible, we are constantly seeking to improve products. If a technological change occurs after a product is on the market, we will implement that technology in future production and, if practical, make it available to current users as a retrofit, update or supplement. If you find a discrepancy between your unit and the available documentation, contact your **GlasCraft** distributor to resolve the difference.

Careful study and continued use of this manual will provide a better understanding of the equipment and process, resulting in more efficient operation, longer trouble-free service and faster, easier troubleshooting.



# Section 1 - Installation: Equipment Assembly

## Guardian Line Installation Guide

 *GlasCraft Systems are factory assembled. If any questions arise concerning air or electrical connections, please refer to illustrations located in the forward portion of this User Manual or contact your GlasCraft distributor.*

1. Locate Guardian.
  - a. Locate Guardian on a level surface.
  - b. Do not expose Guardian to rain.

### CAUTION

*Bolt Guardian to original shipping pallet before lifting.*

- c. Use the wheels to move Guardian to a fixed location, or bolt to shipping pallet and move with forklift.
    - d. To mount on a truck bed or trailer, bolt directly to truck or trailer bed.

## 2. Advanced preparation

- a. Before beginning any installation, ensure that the applicator has the desired power supply available, (i.e. 220V single phase / 380V three phase), within 10 ft. of where the machine is to be placed. If the machine needs to be further than 10 ft. from the power supply, additional lengths of properly sized electrical cable will be required.



**Never use a smaller gauge size than supplied by the factory!**

- b. Depending on the electrical setup, it may be necessary to install an appropriate plug on the end of the cable. GlasCraft will not supply this plug, as we are unaware of which style will be needed.
  - c. Consult the data sheet for the specific unit being installed to determine the proper breaker size needed.

- d. You will need to run an air line to the area where the machine will be placed. consult the data sheet the specific unit being installed to determine much clean, dry air will be needed to supply the machine. If the air line is **under** 25 ft. use a minimum of 1/2 in. I.D. pipe or hose. If the air line is **longer** than 25 ft., use a minimum of 3/4 in. pipe or hose. Anything smaller than these diameters will severely affect the machine's performance!



**Do not use any quick disconnect fittings on the main air line going to the machine!**



*Check your air-compressor to make sure it is capable of supplying the maximum amount of air that the machine requires. All GlasCraft equipment is rated at 25 CFM (cubic foot per minute) 708 liters at 90- 100 psi (.62-0.7 MPa, 6.3-7.7 bar) do not exceed 125 psi (0.86 MPa, 8.6 bar).*

3. Move material drums to the area that the equipment will be placed, ensuring that they are not sitting directly on the floor. Simply place the drums on top of a pallet or similar device, so the drum bottoms will not be in contact with any cold surfaces.
4. Open all boxes that came with the machine and verify that all items are accounted for.
5. Install feed pumps (purchased separately) in POLY and ISO material drums.
6. Install a "y" filter (provided in transfer kit) to the outlet of both pumps. *Be sure to use PTFE tape on the threads.*

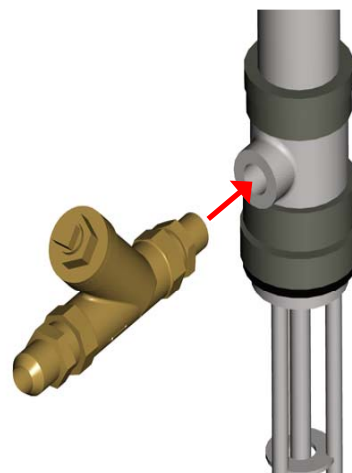

## Section 1 - Installation: Equipment Assembly

7. Seal component A drum and use desiccant dryer.
8. See transfer pump manual for setup instructions.
9. Remove the metal caps from the material pumps.

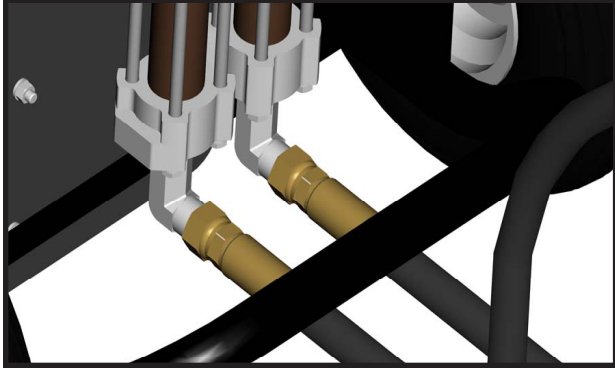

10. Connect one end of each material hose to the inlet fittings located on the back of the machine. *It is highly recommended that you label the (POLY) hose with BLUE tape and the (ISO) hose with RED tape to ensure that you don't put the wrong transfer pump in the opposite material drum.*

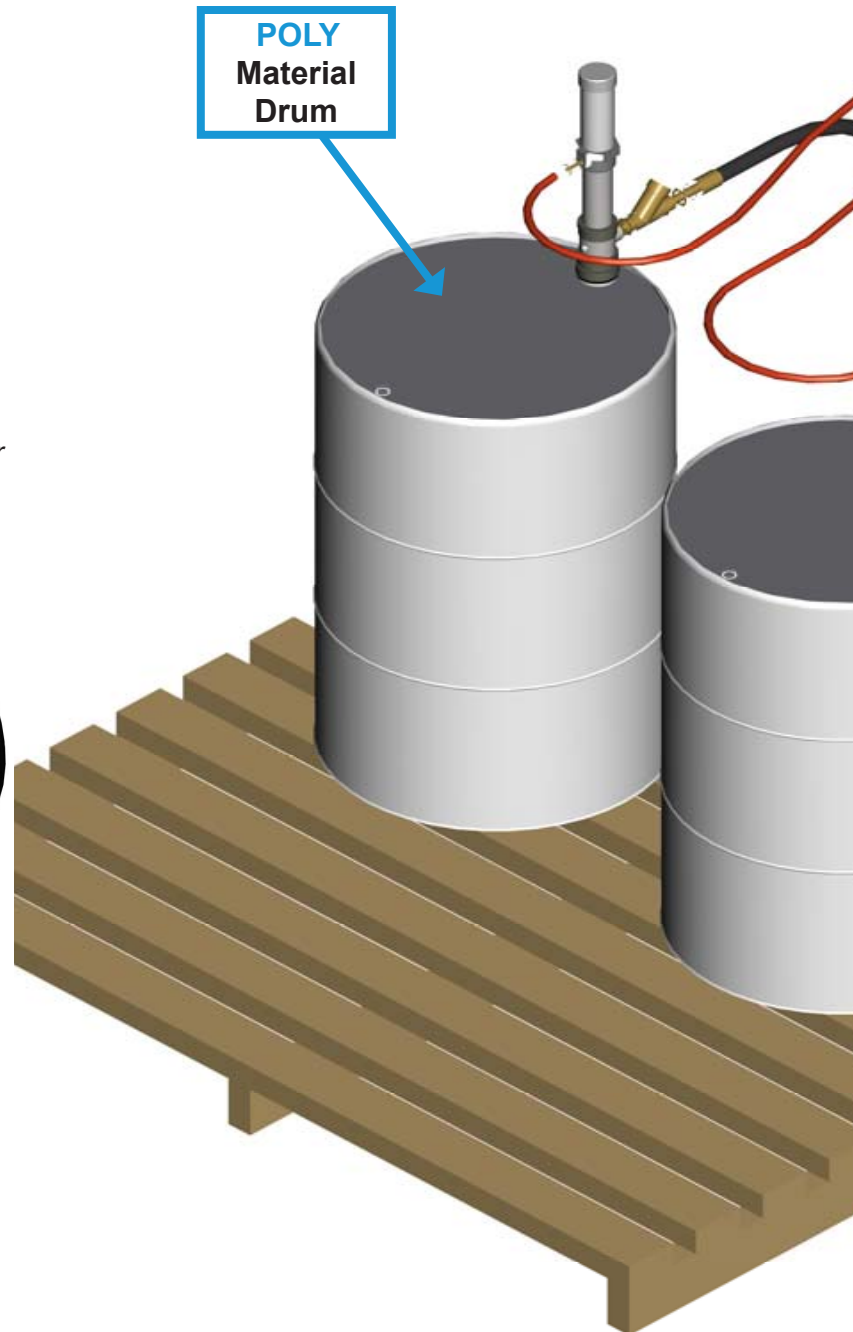
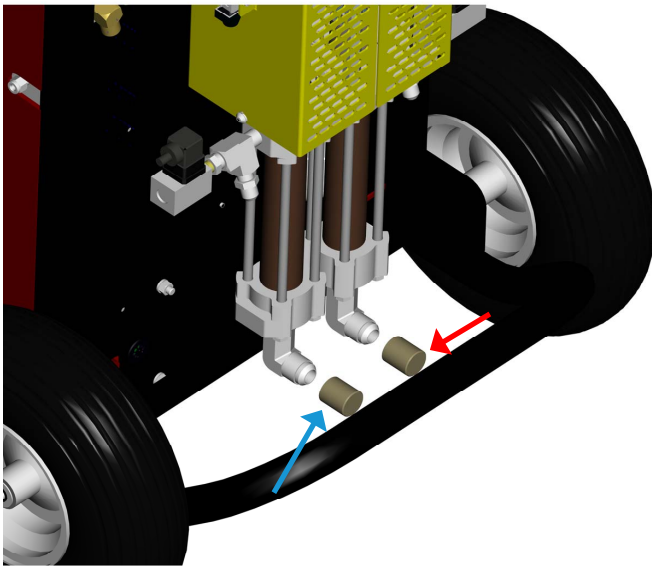

## Section 1 - Installation: Equipment Assembly

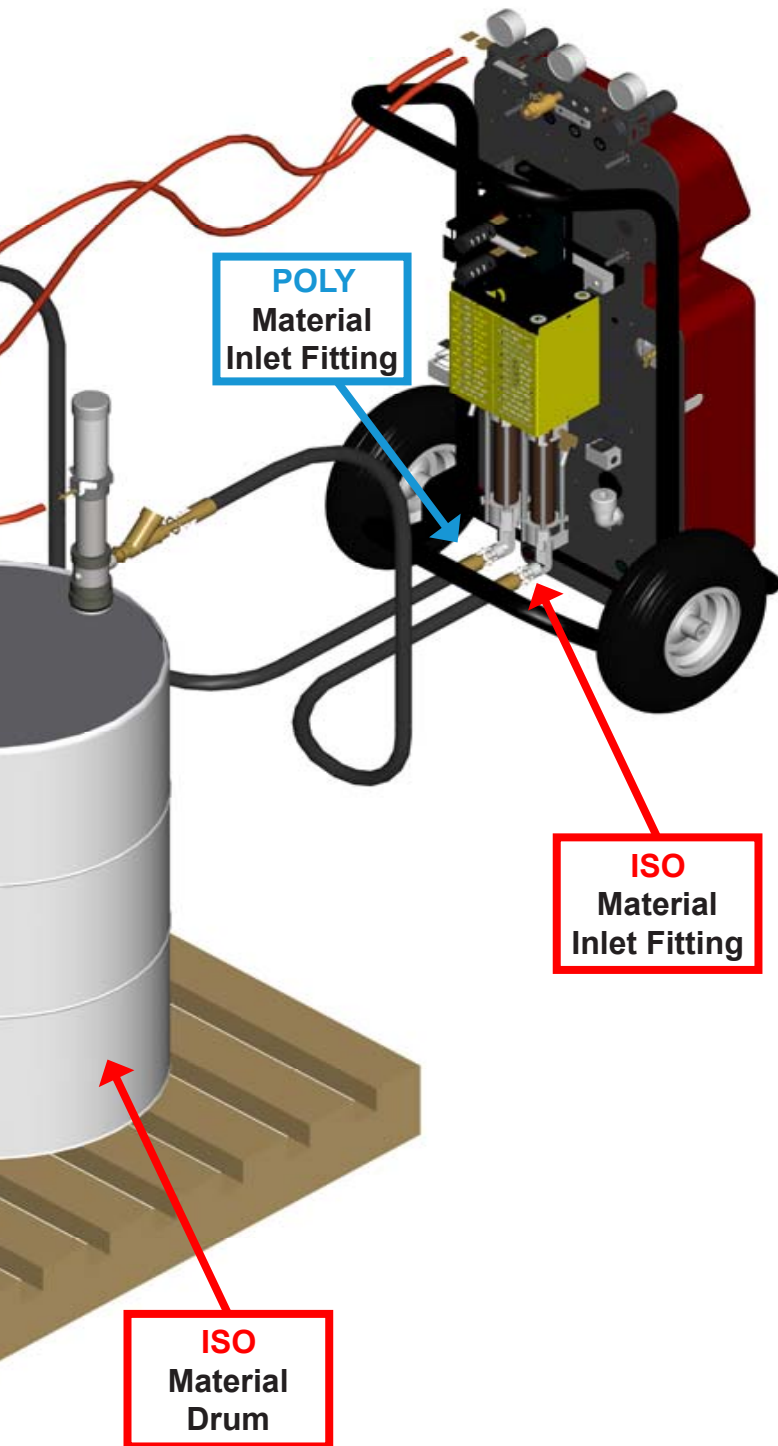

11. Connect the other end of the material hoses to their correct transfer pumps. Ensure that they are not reversed and tighten securely.

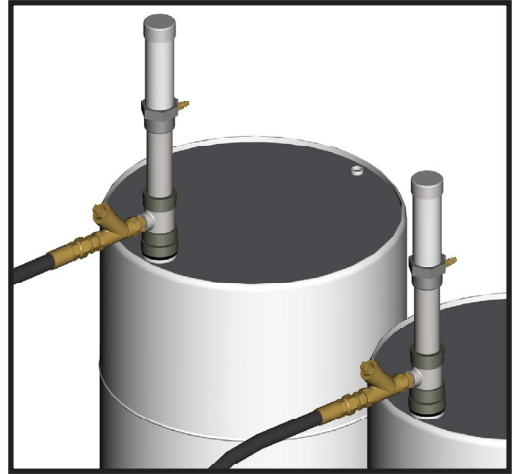

12. Attach the other end of the airlines to the far right regulator on the machine's air manifold.

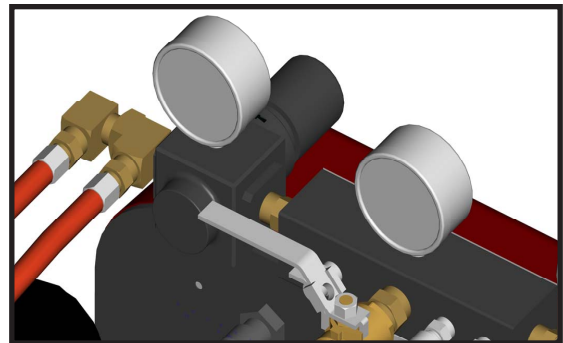

## Section 1 - Installation: Equipment Assembly



Main power from power source should be disconnected or turned off to console before making hose connections.

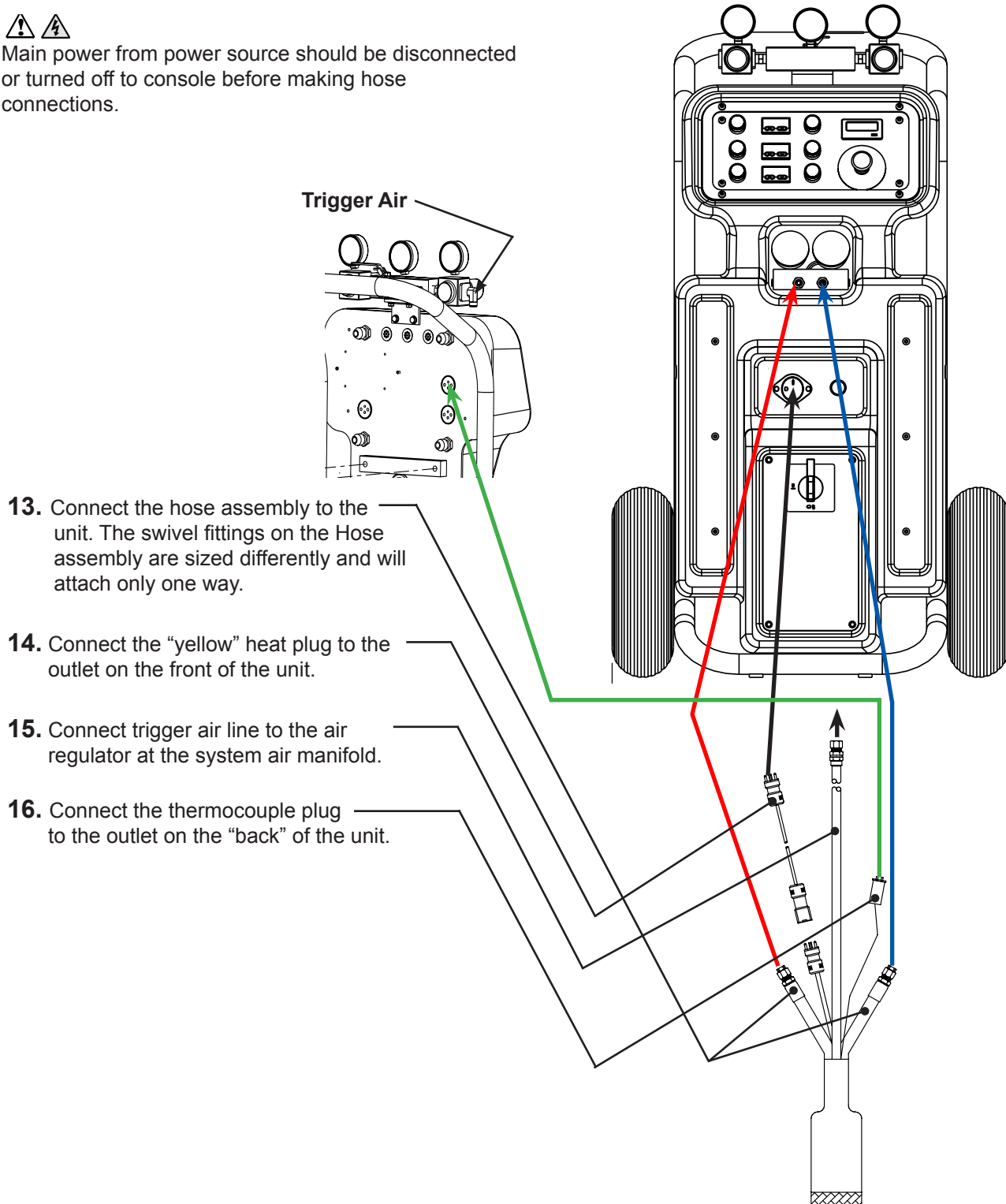

## Section 1 - Installation: Equipment Assembly

17. Continue adding extra hose lengths if necessary.

 *The GlasCraft System is factory assembled. If any questions arise concerning air or electrical connections, please refer to illustrations located in the forward portion of this User Manual or contact your GlasCraft distributor.*

**Required Tools:**

Opened - end wrenches - 5/8", 3/4", 13/16"

- a. Lay hoses out straight.
- b. Couple hoses together with supplied union fittings and tighten finger-tight.
- c. • Hold crimp fitting hex (3/4"), and union fitting together, allowing the hose to hold it's natural line.
  - Using the appropriate wrench (A-side 3/4" / B-side 13/16") tighten swivel fitting to union, not allowing crimp fitting or union to turn. Repeat on opposite side of union.

**This practice is required on all connection points.**

- 1) Hose @ machine
- 2) Hose @ gun
- 3) Adding additional hose sections

- d. Attach the yellow power plugs.
- e. Attach the thermocouple extension cable. p/n 21998-00

GC0705 Extension hose  
Machine End

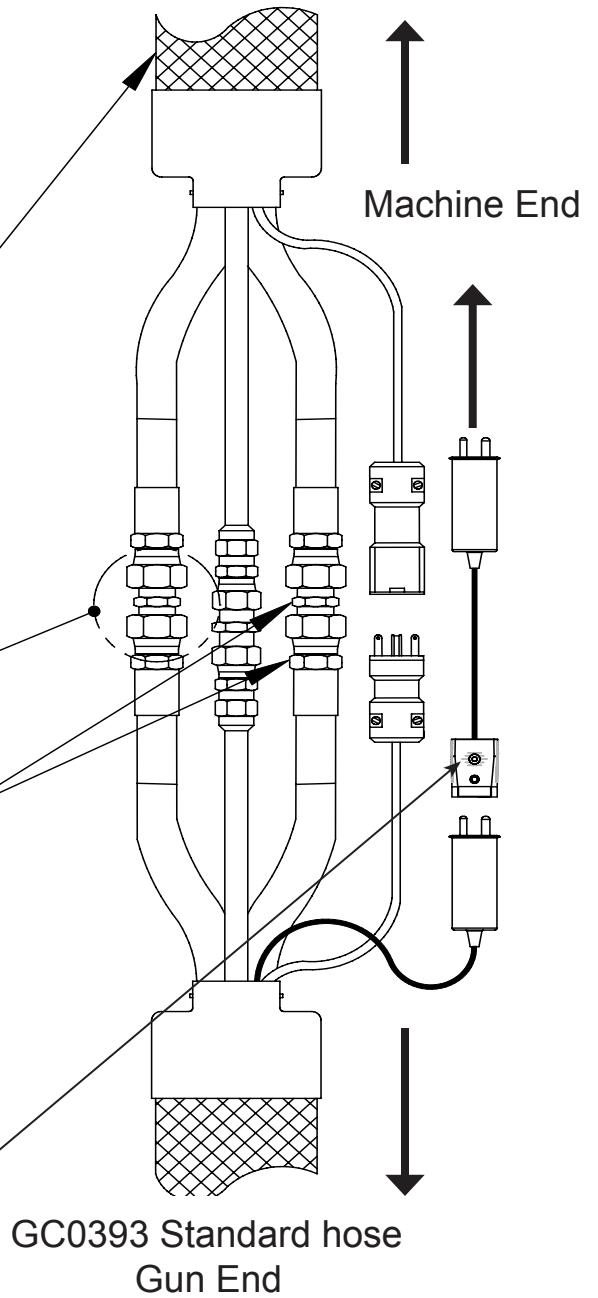

## Section 1 - Installation: Equipment Assembly

18. Connect the hose assembly to the spray gun as shown.

19. All connections should now be **tight!**

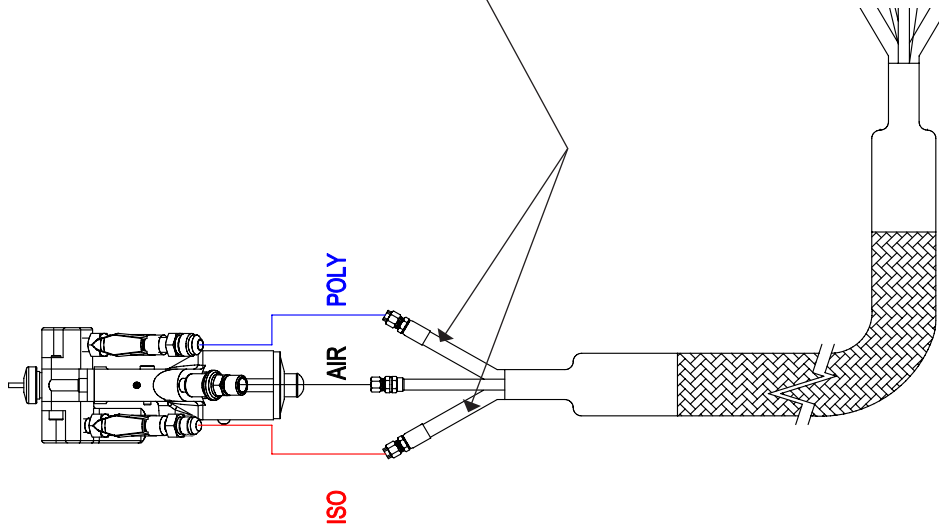

When Main Power to system console is on, the white and black wires in the console are **always live!** Disconnect or turn **off** Main Power source before opening console to make any repairs or before making any electrical repair of any type to the system.



If you do not understand the electrical hook-up described above, consult your local GlasCraft distributor OR a qualified electrician.



Electrical connections must be checked on a periodic basis.

20. Connect the white and black wires of the Power cord to a single phase of 208/240 VAC, 50/60 HZ. The green wire should be connected to GROUND

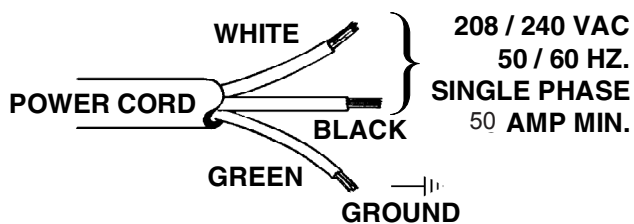



## Section 2 - Operation: Start-Up Instructions



Never leave machine unattended while system power is on or system is running.  
System running is defined as: preheat cycle of the hose heat, primary heaters, or any pump operation.  
Machine operators must be familiar with the component functions and operation of the machine.

### Pre-Operation Check List

- A. Check that all fittings are securely tight.
- B. Check electrical hook-up (qualified electrician recommended).
- C. Main power switch on control box should be switched to **OFF** position.
- D. Air regulator turned (counter clock-wise) to **OFF** position.
- E. Hose control and primary heater control to **OFF** position.



Do not place any part of the body in the path of the material spray.  
Do not point the gun at or near other personnel.  
Do not look into the mixing chamber orifice at any time.  
Because of the hazardous materials used in this equipment, it is recommended that the operator use an air mask, goggles, protective clothing, and other safety equipment as prescribed by current regulations, recommendations of the chemical suppliers, and the laws in the area where the equipment is being used.

### Initial Start-Up Procedure

With all material and air lines connected and power cable attached, the system is now ready for start-up.

### Filling The System

1. Adjust air regulator to 20 psi to fill system. Air motor will cycle slowly to fill pumps, heaters and hoses and stop.

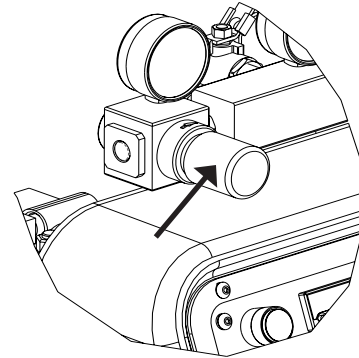

2. Remove ISO & POLY side blocks from gun.

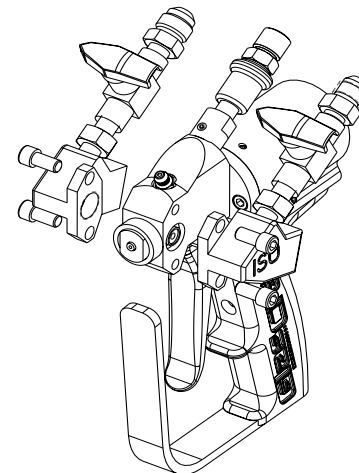

**PROBLER P2  
MAKE SURE VALVES ARE OFF**

## Section 2 - Operation: Start-Up Instructions

- Place separate clean containers under each individual side block. **Slowly** open material valves (black arrow forward) on each side block to allow trapped air to escape the hose and material to flow into the containers until all air is purged from the material system.

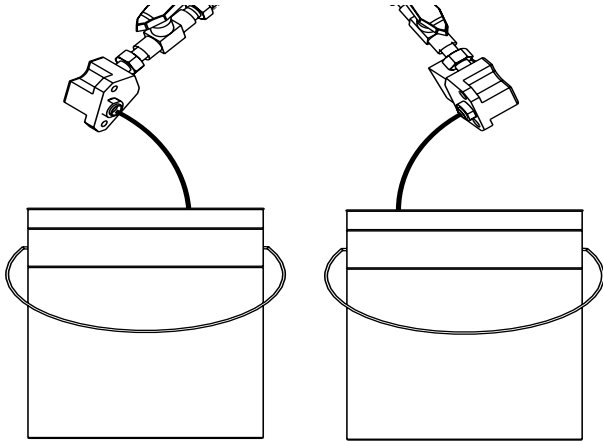

- Clean and lubricate side blocks and seals thoroughly and re-assemble on gun. Make certain that the side block screws are tightened securely.
- Refer to material manufacturers operating instructions for proper preparation of material, i.e., mixers, etc.
- Leave air regulator at 20 psi.

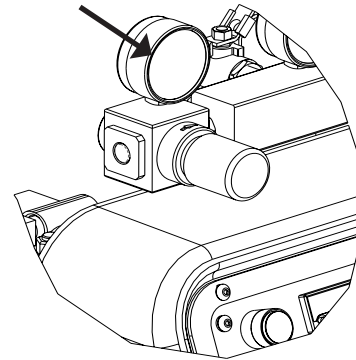

- Turn main power switch to **ON** position.

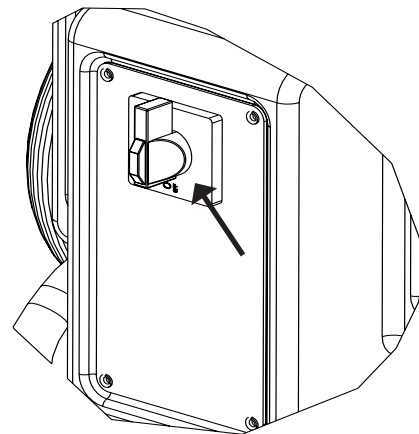

- Turn on Hose Control:
  - Push in the green power button.
  - Press up or down arrow buttons on the controller until desired temperature setting is achieved.

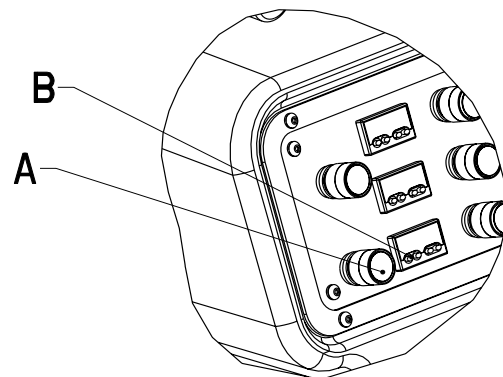

 Remember to dispense one to two gallons of material to clear the system of grease and plasticizer that was used during factory testing.

- Close manual material valves. Material pressure gauges should now register approximately equal pressure. If one side registers considerably more pressure than the other side, go to the high pressure side and bleed off some pressure by slightly opening the manual material valve on the side block over the container. Bleed pressure until both sides are approximately the same pressure.
- Dispose of waste material properly and in accordance with chemical suppliers instructions and local, state and federal regulations.

 Before re-assembling side blocks, lubrication can be applied by dabbing a white lithium grease into holes inside of gun front housing and wiping grease over side block seals. Grease will purge itself when air valve is turned on at gun and gun is triggered.

## Section 2 - Operation: Start-Up Instructions

11. Turn on the ISO & POLY heater control:
  - a. Push in green power button.
  - b. Press up or down arrow buttons on the controller until desired temperature setting is achieved.

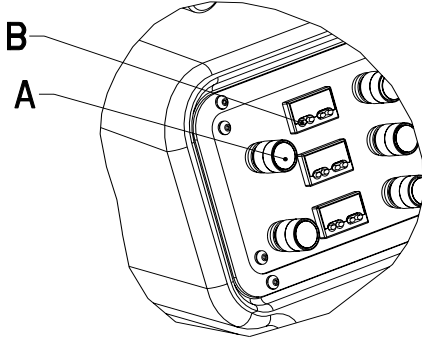

*Straighten hose out flat, to avoid uneven heating and damage to internal wiring of the Hose Assembly.*

 *Allow enough time for hose to warm up (approximately 15- 20 minutes). Remember that the heated hose does not have a delta rating. The heated hose's function is to maintain the heat generated by the primary heaters during system operation, and preheat material during initial start-up. The hose should be set to maintain a temperature close to the set point of the heaters.*



*Due to the expansion of urethanes when heated, it is imperative that on cold start-up of the system that the heaters be turned on and allowed to reach operating temperatures before the main pump air regulator is adjusted to the desired spray pressure. If you do not allow the heaters to reach operating temperature before adjusting air pressure, the material pressure will exceed the set point of the over pressure switches causing the system to shut down.*

12. Adjust main air regulator to material suppliers specifications.

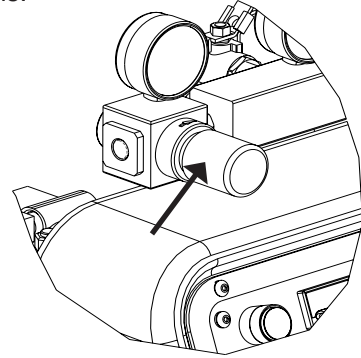

13. Turn purge air and material valves ON at gun.

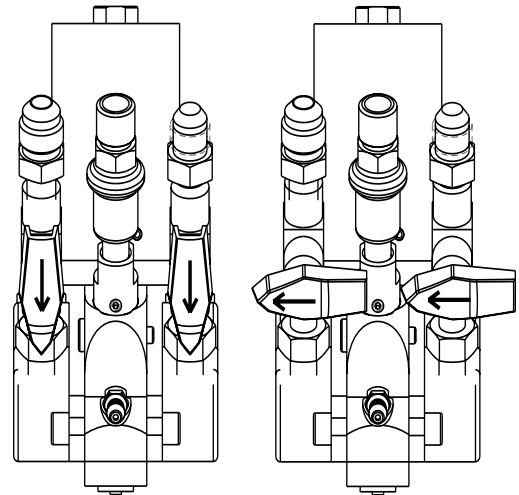

**ON**

**OFF**

14. Relieve any excess pressure by triggering the gun.



*The emergency stop switch is located on the bottom right side of the control panel, when depressed, it will shut down the power and activate the air dump valve. To reset, turn handle on push button.*

15. The system is now ready for operation.

## Section 2 - Operation: Start-Up Instructions







### Change Temperature Controller Display Units (Fahrenheit or Celsius)

220 V units are factory set to display temperature readings in degrees Fahrenheit. 380 V units are factory set to display temperature readings in degrees Celsius.

The temperature display units can be changed with the following procedure:

1. On the Watlow SD31 controller, press and hold the  and  buttons simultaneously for 3 seconds until the display reads "SET". This is the Setup Menu.



2. Scroll through the Setup Menu by pressing the  button until the display reads "C-F" (press  button 3 times).
3. Press and hold the  button to display the current unit setting of "C" or "F".
4. Continue to hold the  button and press the  button to switch to the desired unit setting, "C" or "F".
5. Release the  button.
6. Press the  button to exit the Setup Menu; the temperature display unit is now changed.
7. Complete steps 1-6 for all three controllers (ISO, POLY, HOSE).

 *Do not change any other settings in the Setup Menu. The settings have been factory programmed for optimal performance.*



## Section 2 - Operation: Shut-Down Instructions

### Daily Shut-Down Procedure

1. Turn off hose and heater controllers.

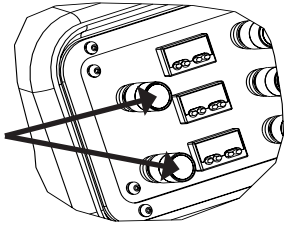

2. Turn off main power switch.

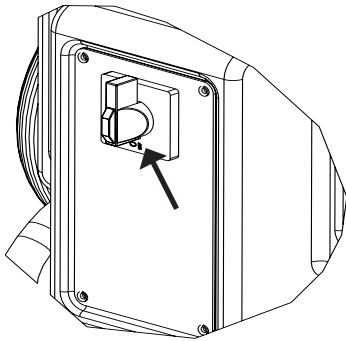

3. Flip retract switch to the “retract position” and trigger the gun until pumps are in the down position.

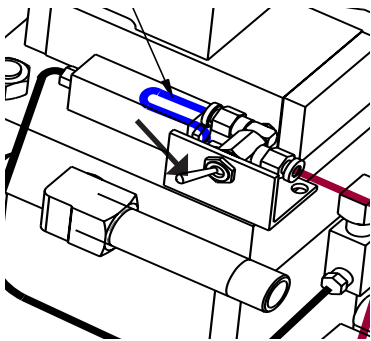

4. Perform gun maintenance. (See gun manual)

5. Reduce main air regulator pressure to zero.

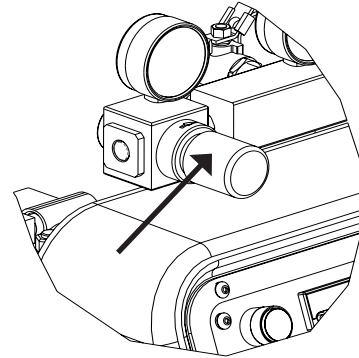

6. Visually inspect the entire system for leaks.

7. Turn off main air supply and main power.

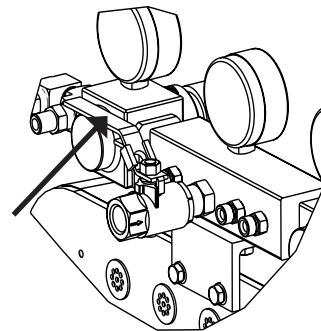

## Section 2 - Operation: Shut-Down Instructions

8. Coil heated hoses with a minimum four foot diameter to avoid kinking and subsequent damage to the internal electrical wiring.
9. Check and lube top of the fluid section.
2. Use a suitable solvent to flush the fluid circuits. To determine the compatibility of solvents with material being used. Always check with material supplier.
3. Increase transfer pump pressure until fluid movement occurs.

Wipe off residual material and add a tablespoon of throat seal liquid (TSL).

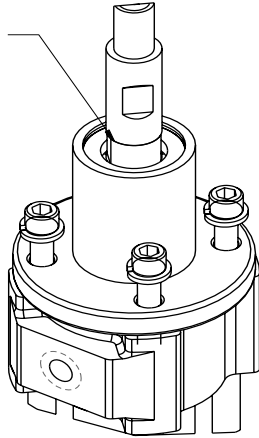

*Do not bleed fluid pressure from the system.*

### Extended Shut-Down Procedure

The following procedure is for long extended shut-down periods.

 *Power should be disconnected and all air regulators turned down to zero.*

1. Remove side blocks from the gun and relieve pressure from the system.

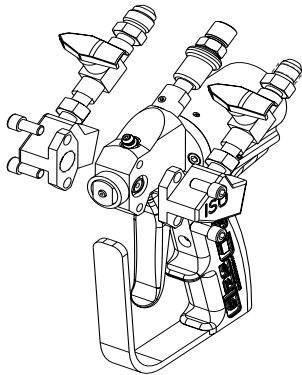

**PROBLER P2**

4. Once primary material is flushed from the system, reduce the main air pressure to zero or flip the retract switch to the "**retract position**" and trigger the gun until the pumps are in the down position.
5. If the solvent used to flush the system also contains plasticizer, ensure that all primary material is flushed from the system and close the ball valves @ the gun.
6. Leave the pumps in the full down stroke position with approximately 200-500 psi. on the fluid gauges.
7. If plasticizer is required to chase out solvent, cycle main pumps until the system is full of plasticizer, then close valves and leave the pumps in the full down stroke position with 200-500 psi.

## Section 2 - Operation: Shut-Down Instructions

8. Turn off main air supply and disconnect air line from the system.

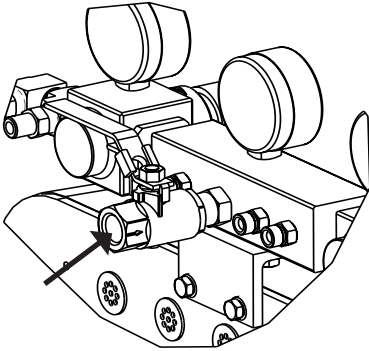

2. Adjust main air regulator to 20 psi.

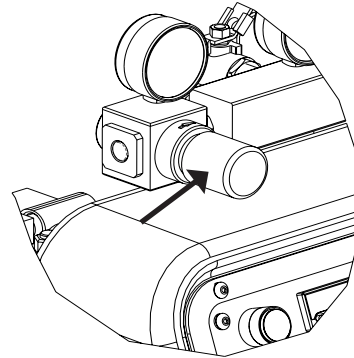

3. Adjust transfer pump regulators to approximately 40 psi.

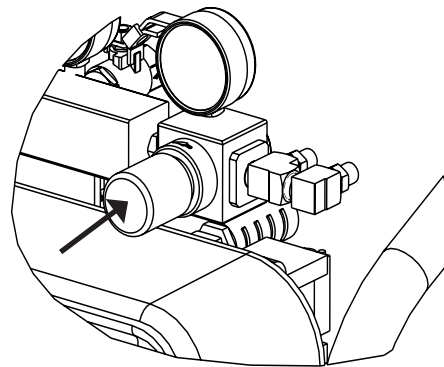

9. Coil the heated hoses with a minimum four foot diameter to avoid kinking and subsequent damage to the internal electrical wiring.
10. For gun shut down, follow the procedure from the gun manual.
11. The length of time a system is shut down, and the climate conditions it's stored in will determine how often the system should be purged and refilled. Usually every 2 - 4 weeks the following procedure should be followed.

4. Remove the side blocks from the gun.

### Purge and Refill Procedure

1. Connect the main air line to the system.

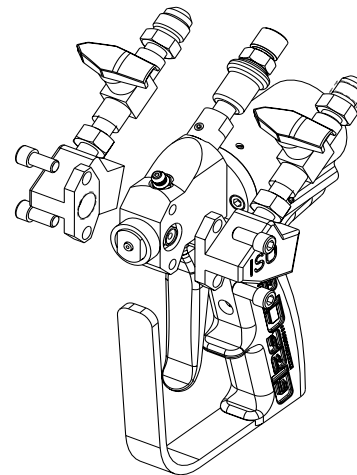
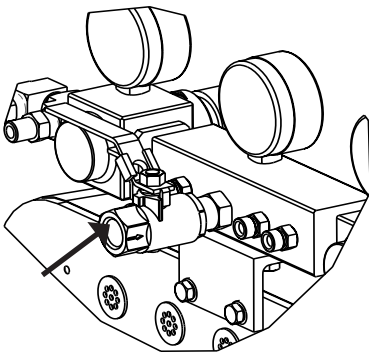

**PROBLER P2**



## Section 2 - Operation: Shut-Down Instructions

5. Open both side blocks simultaneously into separate containers and dispense approximately 1-1/2 - 2 gallons of material from each side or until all plasticizer is purged from the system. Stop the pumps in the down position.

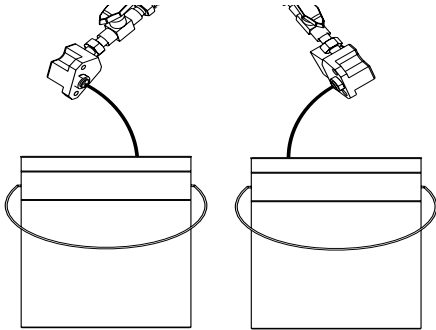

6. Close both side blocks simultaneously and wipe off residue from the side block seals. Regrease and attach both blocks to the gun.
7. Mix and properly dispose of purge material.



*Before performing any repairs on the system, ALL AIR and FLUID PRESSURES SHOULD BE RELIEVED TO ZERO (BLEED-OFF)!*

To relieve Air and Fluid pressures:

System Console:

1. Turn OFF valves that supply material to the pumps.
2. Turn OFF main air regulator on air motor.

Gun:

1. Open both side block material valves.
2. Turn ON air switch.
3. Point gun into a clean, suitable container and trigger gun until material flow stops.
4. Fluid pressure gauges must read zero (0), if not, trigger gun until the fluid pressure gauges do read zero (0) pressure.
5. Turn OFF side block material valves.
6. Trigger gun several more times to purge any material remaining in gun. Turn OFF air switch.
7. Unless system is to be returned to service at once, follow DAILY SHUT-DOWN PROCEDURE



*Before performing any repairs on any part of the system,*

***PLACE ALL CONTROLS ON THE MACHINE AND THE MAIN POWER SOURCE IN THE OFF POSITION AND DISCONNECT THE ELECTRICAL POWER CABLE FROM THE MAIN POWER SOURCE!***

# Section 3 - General Information: Assembly Drawings

## GC1820, GC1822 Unit Assembly

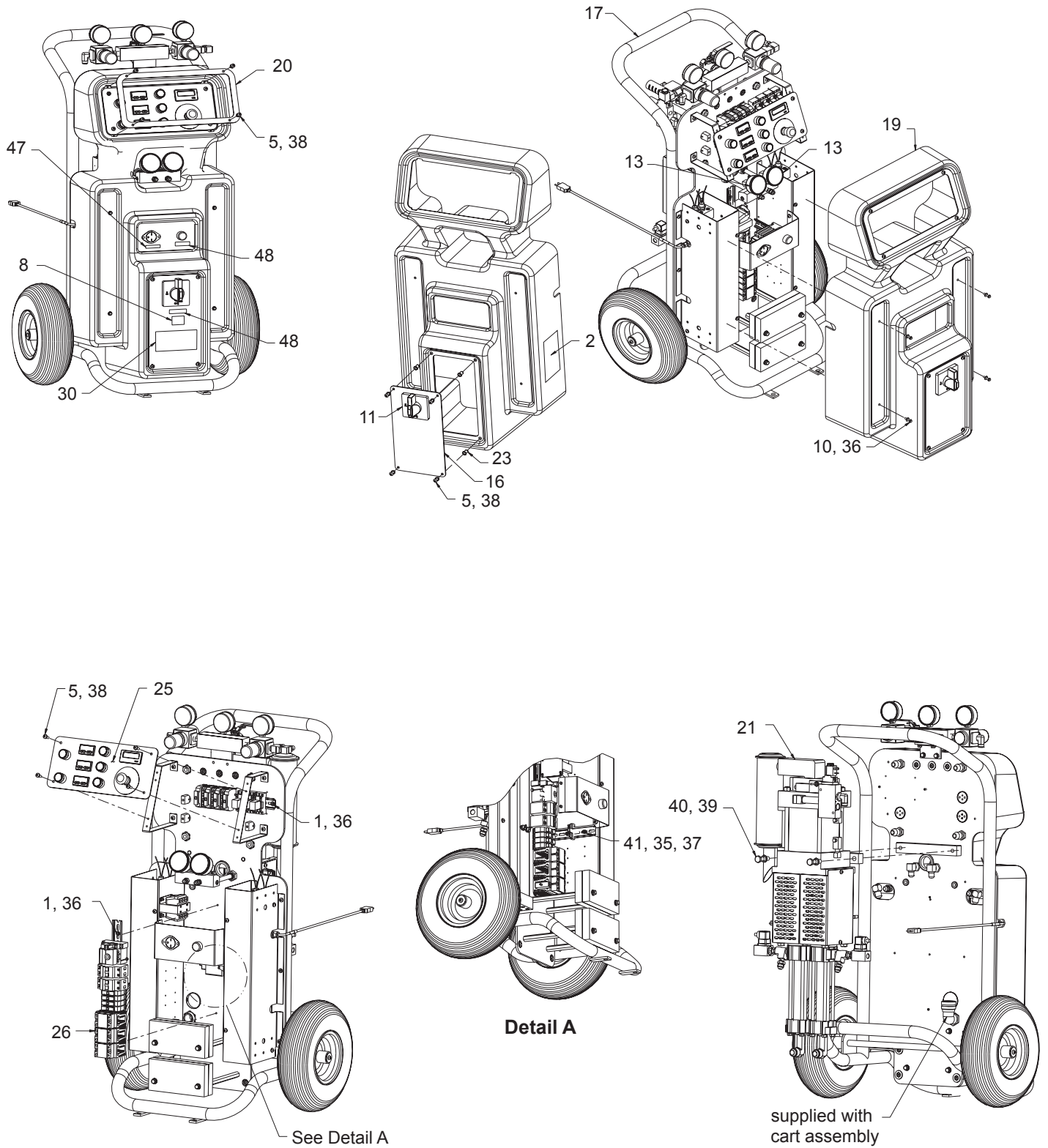

Some parts have been removed for clarity

# Section 3 - General Information: Assembly Drawings

## GC1820, GC1822 Unit Assembly

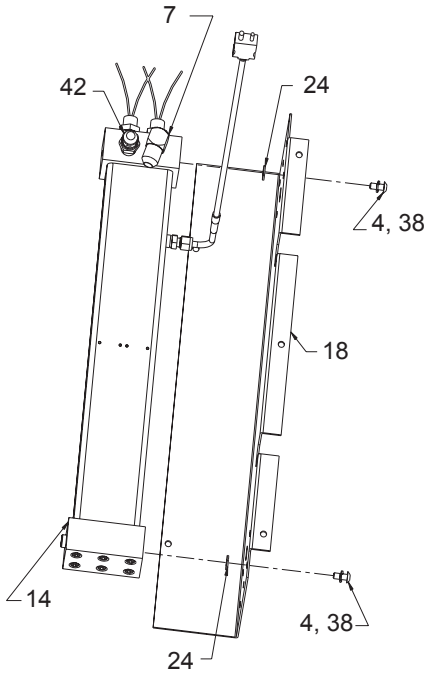

ISO Heater Assy

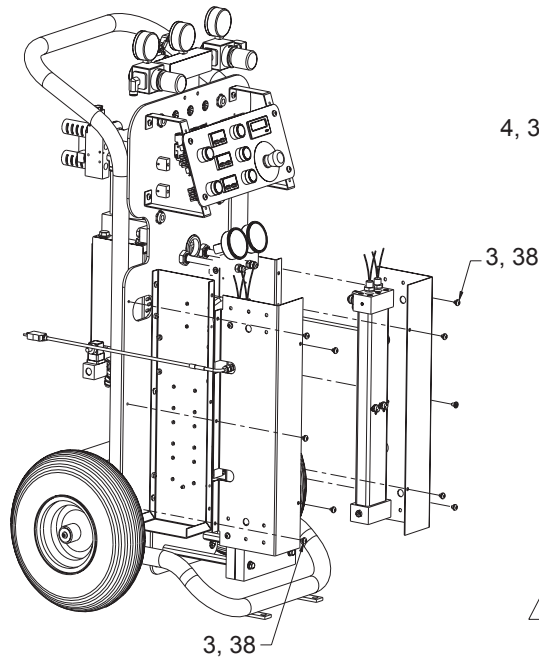

POLY Heater Assy

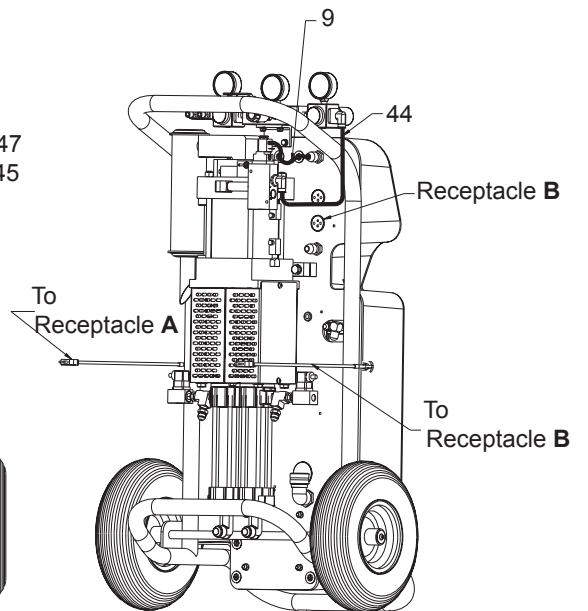
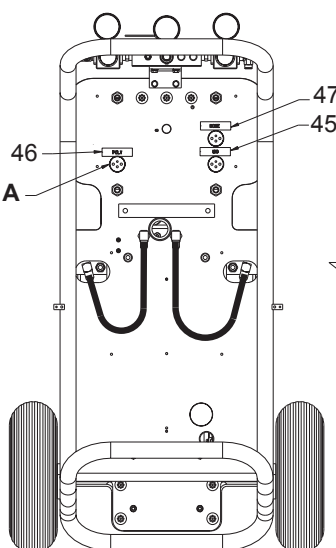
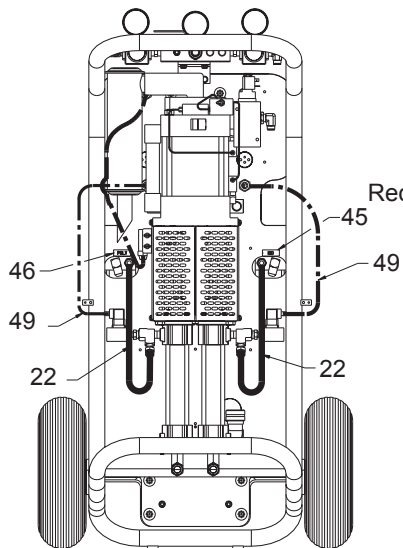

## Section 3 - General Information: Assembly Drawings

### GC1820 Parts List

Ref.	Part	Description	Qty.
1*		RIVET, BLIND, .188 DIA.X .425 STL	5
2 ▲	15G280	LABEL, WARNING	1
3	112925	SCREW, CAP, BTNHD	10
4	GC0433	SCREW, BHDC, SS, .250-20X .625	4
5	GC0434	SCREW, BHDC, SS, .250-20X .875	12
7	GC0578	FITTING, ELBOW, JIC, 3/8NPTM X 3/4UNF S	2
8 ▲	GC0797	LABEL, DECAL, LIVE WIRE	1
9	GC0811	CONNECTOR, CONNECTOR	1
10*		SCREW, SELF-TAP, .190 X 1.000 SS	4
11	GC1071	SWITCH, POWER, ON/OFF	1
12* †		CABLE, POWER; 11 FT	1
13	GC1180	GAUGE, PRESSURE, 5000PSI, BACK MT	2
14	GC1786	HEATER, ASSY, ISO, 4 ROD	1
15	GC1787	HEATER, ASSY, POLY, 4 ROD	1
16	GC1718	PLATE, BOTTOM, GUARDIAN	1
17		CART, ASSY, GUARDIAN, IP, SEE PAGE 30	1
18	GC1725	COVER, HEATER, S, A5-6000	2
19	GC1726	COVER, SHELL, FIBERGLASS, GUARDIAN	1
20	GC1730	RING, PANEL, CONTROL, GUARDIAN	1
21	GC1735	PUMP, PUMP, A6 GUARDIAN SERIES; SEE PUMP MANUAL 313277	1
22	GC1744	HOSE, ASSY	2
23*		NUT, RIVET	4
24	GC1746	WASHER, FIBER	4
25		CONTROL PANEL, GUARDIAN; SEE PAGE 32	1
26		CONTROL, ELECTRICAL	1
30	GC1791	LABEL, DECAL, GUARDIAN, A6-6000 IP	1
35	GC2052	WASHER, FLAT	2
36*		WASHER, FLAT	9
37	GC2107	WASHER, LOCK, SPRING	2
38	GC2109	WASHER, LOCK, SPRING	26
39	GC2112	WASHER, LOCK, SPRING	2
40	GC2175	SCREW, HXHD, CS, .500-13X2.000ZP	2
41	GC2192	SCREW, SHDC, SS, .164-32X .375SST	2
42	GC2203	FITTING, CONNECTOR	2

Ref.	Part	Description	Qty.
44*		HOSE, TUBNG, P.E., .500 OD NATURAL	1.5
45	GC2363	LABEL, DECAL, ISO	2.
46	GC2364	LABEL, DECAL, POLY	2
47	GC2365	LABEL, DECAL, HOSE	2
48	GC2368	LABEL, DECAL, MAIN	2
49	GC0805	SWITCH, PRESSURE, HIGH	2

\* Source locally.

† Not Shown.

▲ Replacement Danger and warning labels, tags, and cards are available at no cost.

### Electrical Control (26)

UNIT	26	Description
GC1826	GC1768	CONTROL, A6-12000 IP, 220V, 1 PH
GC1828	GC1769	CONTROL, A6-12000 IP, 220V, 3 PH

# Section 3 - General Information: Assembly Drawings

## GC1826, GC1828 Generic System Schematic

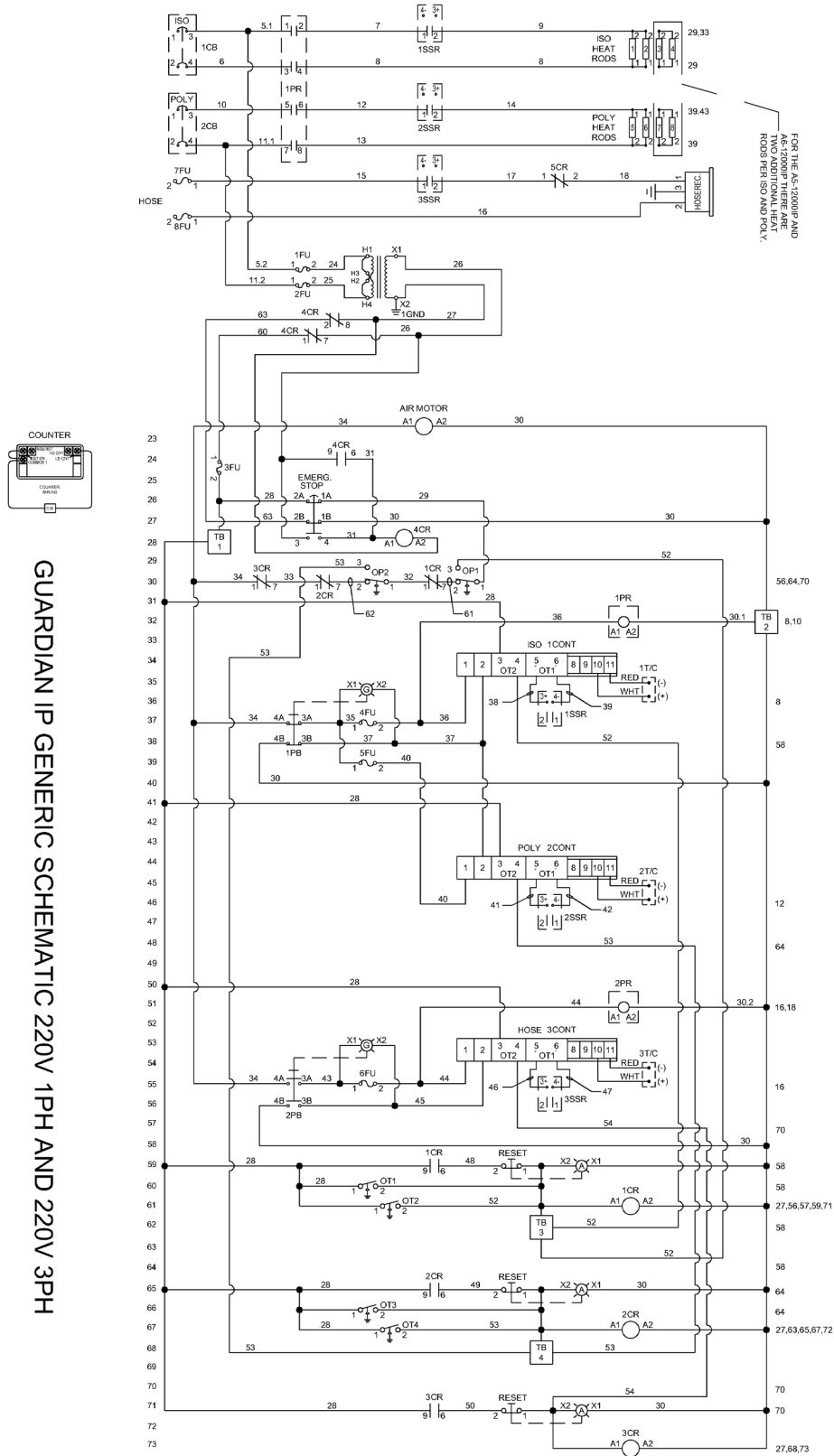

# Section 3 - General Information: Assembly Drawings

## GC1826, GC1828 System Schematic 220V Single Phase

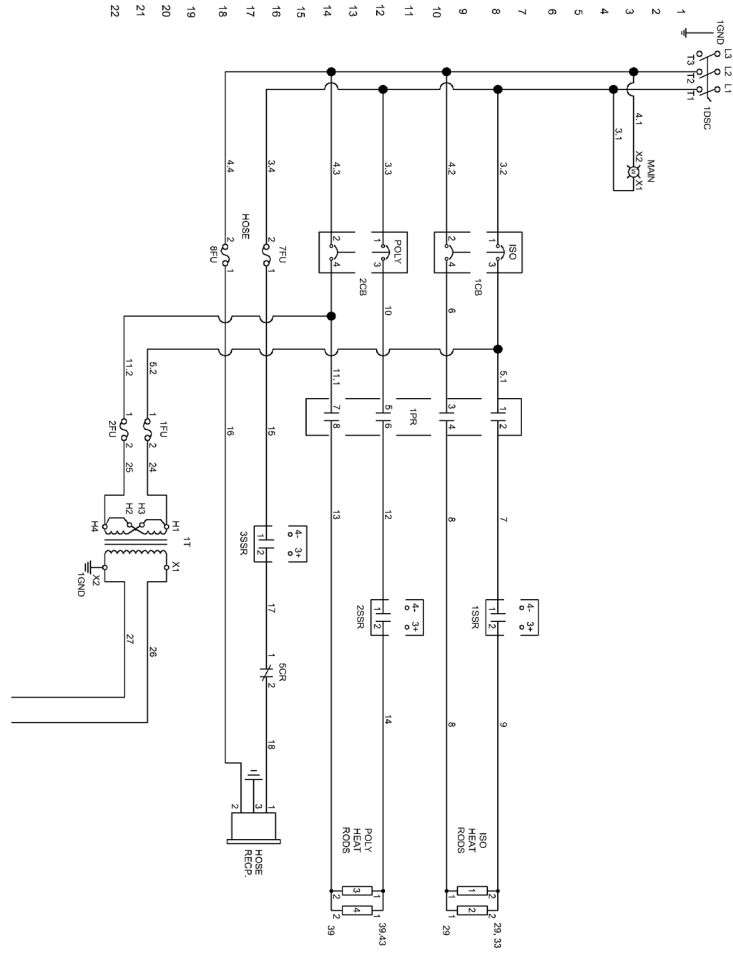

220 VOLT SINGLE PHASE ONLY

- #18 GA. BLACK WIRE \_\_\_\_\_
- #14 GA. BLACK WIRE \_\_\_\_\_
- #10 GA. BLACK WIRE - - - - -

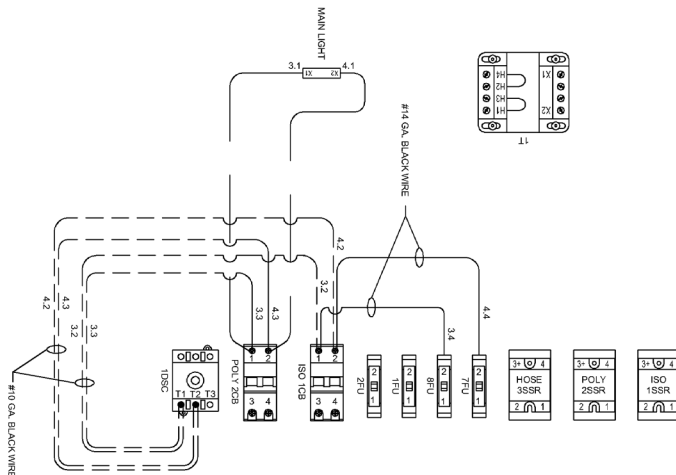

# Section 3 - General Information: Assembly Drawings

## GC1826, GC1828 System Schematic 220V Three Phase

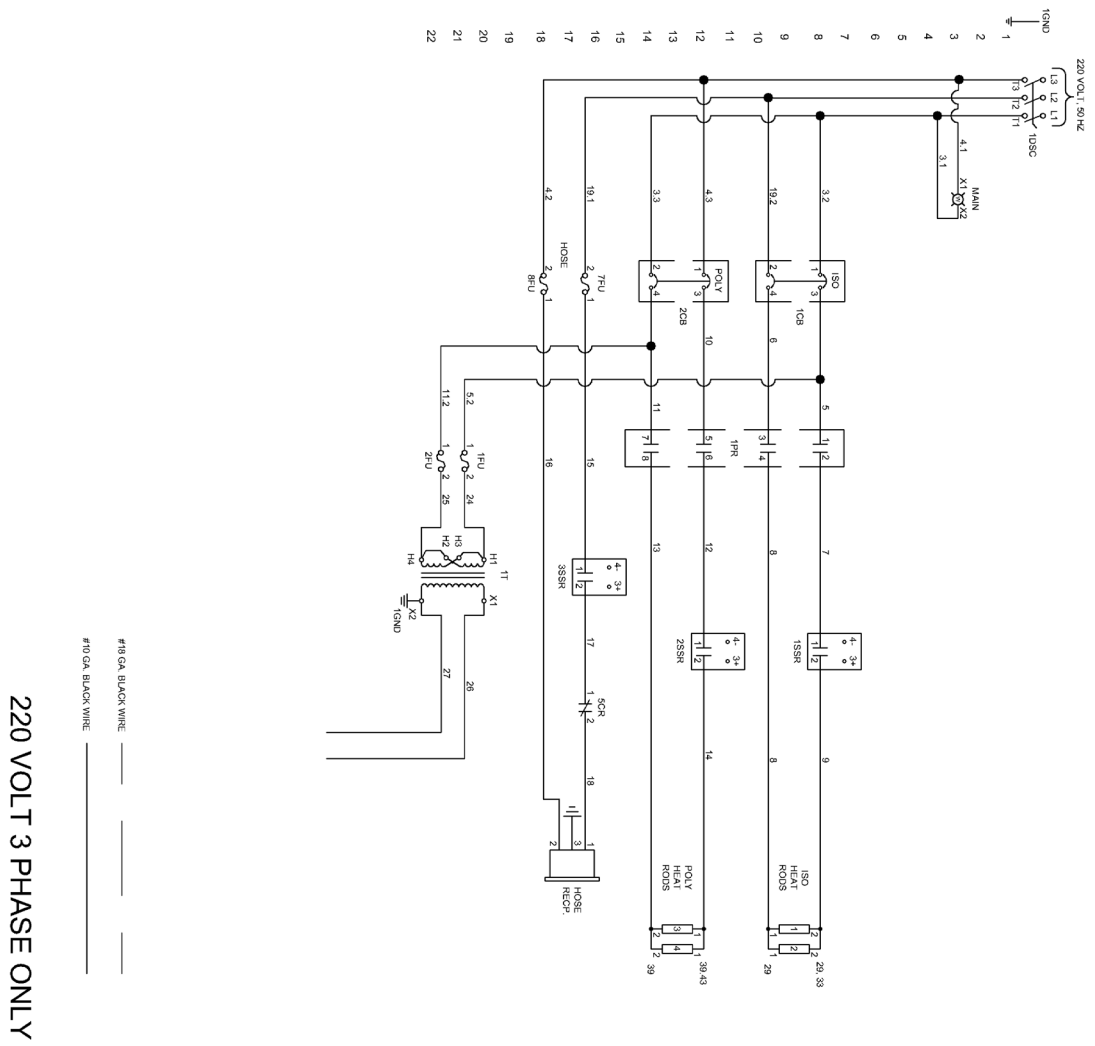

#18 GA. BLACK WIRE \_\_\_\_\_  
 #10 GA. BLACK WIRE \_\_\_\_\_

220 VOLT 3 PHASE ONLY

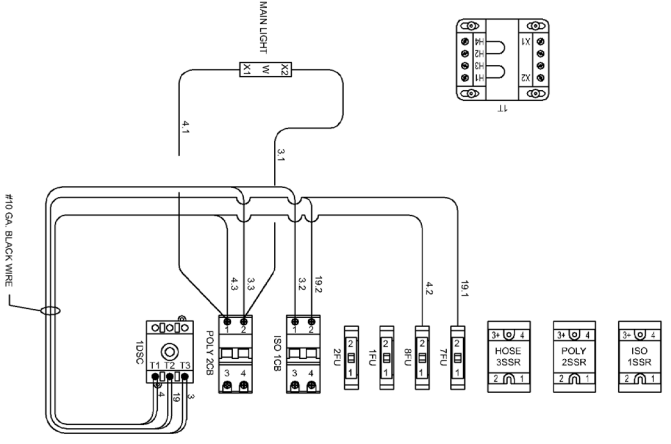

# Section 3 - General Information: Sub Assembly Drawings

## Cart Assembly IP

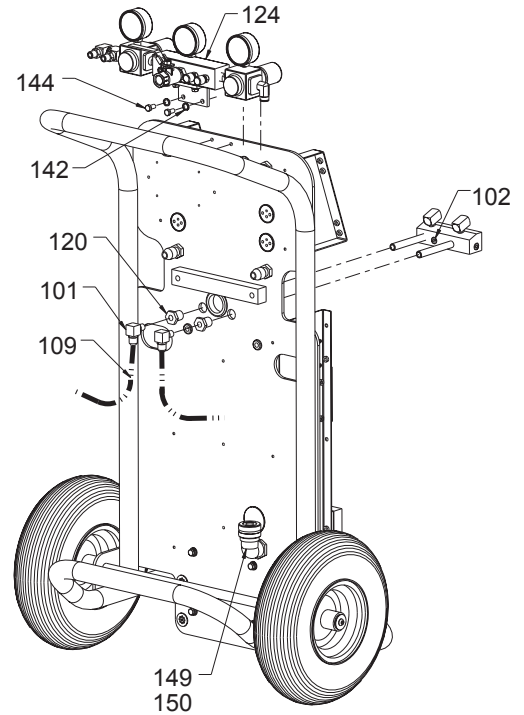
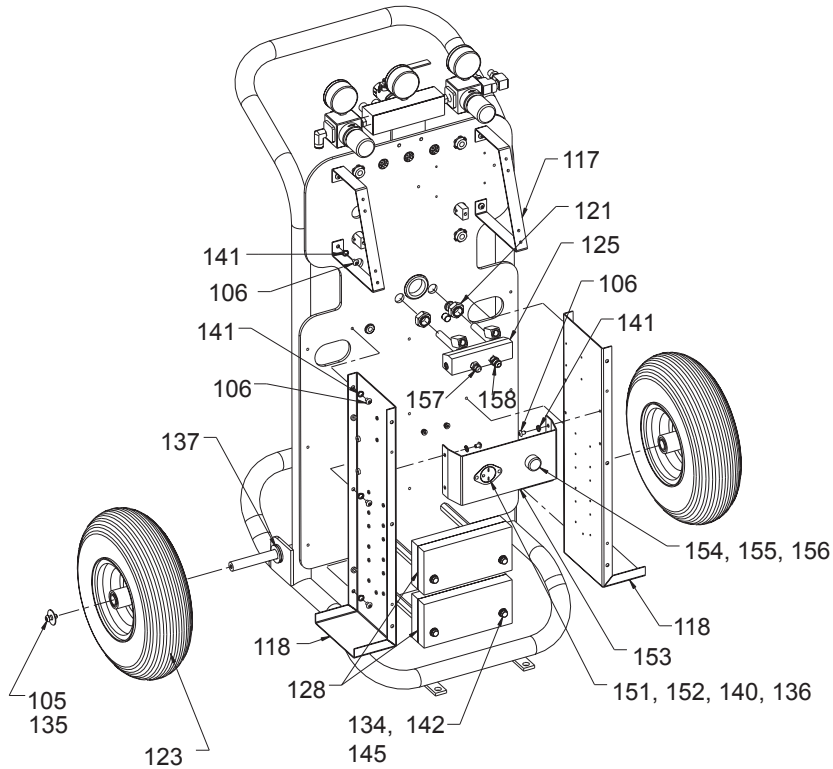

Some Parts Removed For Clarity

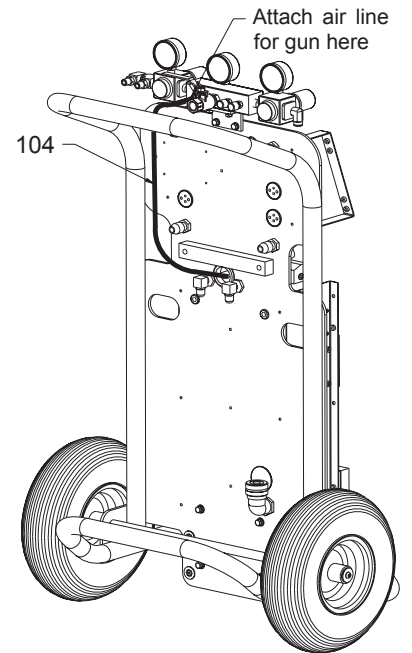
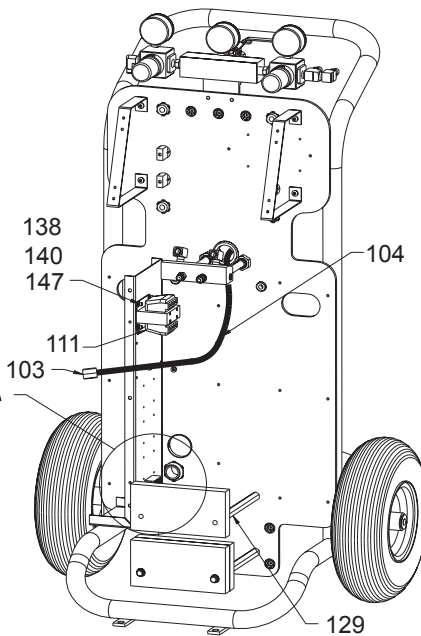
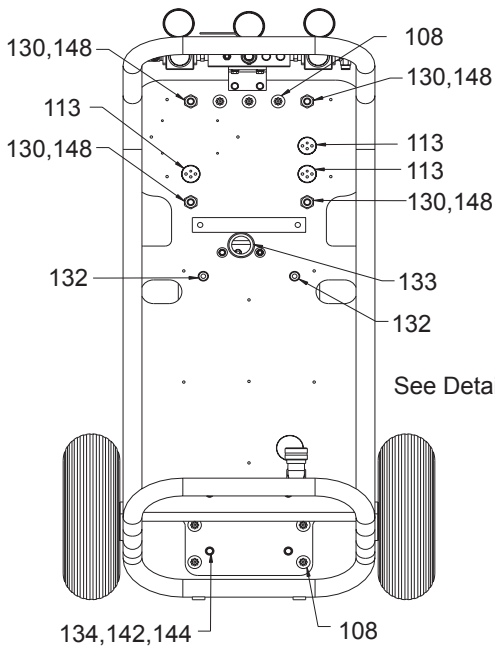

Some Parts Removed For Clarity

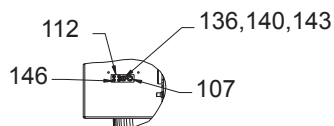

Detail A



## Section 3 - General Information: Sub Assembly Drawings

### Cart Assembly IP

Ref.	Part	Description	Qty.
101	GC0012	ELBOW	2
102	GC0025	PLUG, PIPE	1
103	GC0217	FITTING, ADAPTER, NPSM, 1/4 X 1/4	1
104	GC0286	HOSE, ASSY	1
105	GC0409	SCREW, BHDC, SS, .312-18X .750	2
106	112925	SCREW, CAP, BTNHD	10
107	GC0437	SCREW, SET, SOC., 7/16-20 X 3/8	1
108*		RETAINER, PLUG, VENT, RETAINER	7
109	GC0790	HOSE, ASSY	2
111	GC0999	TRANSFORMER, BOX, CONTROL	1
112	GC1040	CONNECTOR	1
113	15W209	JACK, PANEL, CIRCULAR	3
117	GC1719	HANGER, PANEL, CONTROL	2
118	GC1723	COVER, HEATER	2
120	GC1738	FITTING, BULKHEAD, 1/4 NPT X 1/4 NPT	2
121	GC1739	NUT, BULKHEAD, 3/4-16	2
123	GC1743	WHEEL	2
124	GC1749	MANIFOLD, ASSY, AIR	1
125	GC1754	MANIFOLD, ASSY, FLUID	1
128	GC1810	COUNTER, WEIGHT	4
129	GC1811	EXTENSION, STANDOFF	4
130	GC1999	NUT, CONDUIT, ELEC., 1/2	4
132*		GROMMET, RUBBER, 3/8 THRU, 1/4PT	2
133*		GROMMET, RUBBER, 1-1/2 THRU, 1/4PT	1
134	GC2044	WASHER, FLAT	8
135	GC2045	WASHER, FLAT, FENDER	2
136	GC2048	WASHER, FLAT, STD	1
137*		WASHER, FLAT, STD	4
138	GC2052	WASHER, FLAT, STD	4
140	GC2107	WASHER, LOCK, SPRING	5
141	GC2109	WASHER, LOCK, SPRING	10
142	GC2110	WASHER, LOCK, SPRING	10

Ref.	Part	Description	Qty.
143	GC2119	SCREW	1
144	GC2180	SCREW	6
145	GC2185	SCREW	4
146*		SCREW	4
147	GC2192	SCREW	4
148	GC2372	GRIP, CORD	4
149*		NUT, CONDUIT	1
150*		CONNECTOR	1
151	GC0796	SOLVENT, RECEPTACLE	1
152	GC2092	NUT, HEX, STD, 8-32	2
153	GC1740	BRACKET, RECEPTACLE, HOSE	1
154	GC1612	PLATE, COUPLING	1
155	GC1621	LIGHT, PILOT, WHITE	1
156	GC1625	LIGHT, LED, WHITE, 240V	1
157	GC2207	FITTING, #6 JIC x 1/4 NPT	1
158	GC0242	FITTING, 5/8-18 SAE X 1/4 NPT	1

\* Source locally.

Part	Description	Qty.
GC0020	FITTING	3
GC0222	REGULATOR, AIR	2
GC0240	GAUGE, AIR,	2
GC0241	GAUGE, AIR	1
*	FITTING, ELBOW	1
GC0755	VALVE, BALL	1
GC1720	BRACKET, L	1
GC1732	MANIFOLD, AIR	1
GC0000	CAP, OILER	2
GC0001	GASKET, CAP, OILER	4
GC1994	FITTING, ELBOW	1
GC2016	FITTING, PIPE, TEE	1
GC2110	WASHER, LOCK, SPRING	2
GC2167	FITTING, PIPE, NIPPLE, HEX	2
GC2169	FITTING, PIPE, NIPPLE, HEX	2
GC2170	FITTING, PIPE, NIPPLE, HEX	1
GC2179	SCREW	2
GC1772	LABEL, GLASCRAFT, MANIFOLD, GRDN	1

## Section 3 - General Information: Sub Assembly Drawings

### Control Panel Assembly

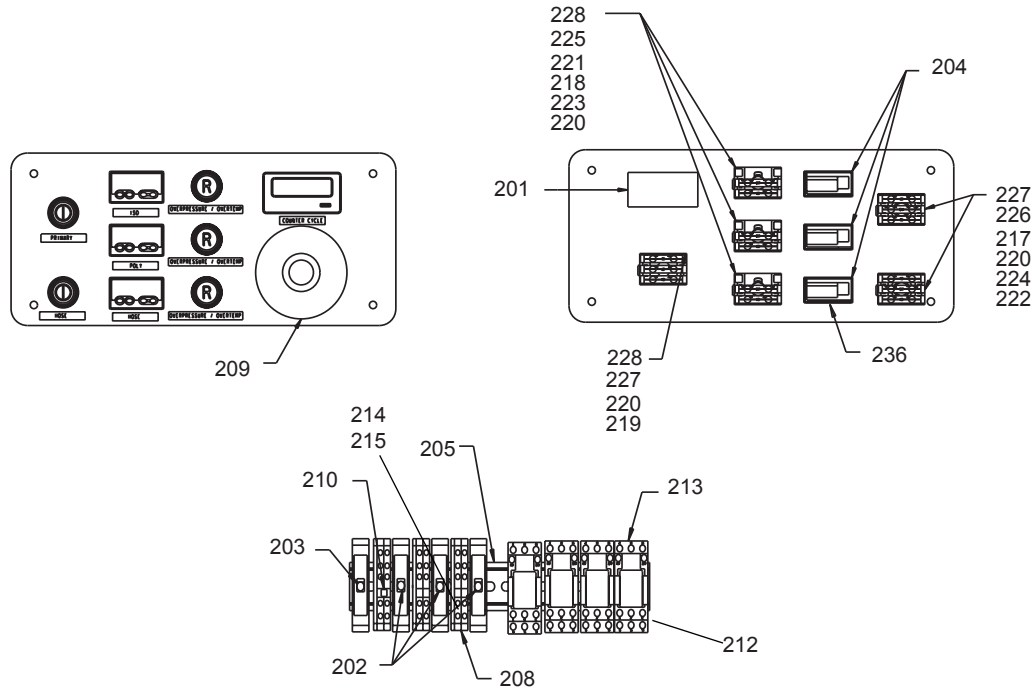

Ref.	Part	Description	Qty.
201	GC0584	COUNTER, LCD	1
202	GC0599	FUSE, 1/2 AMP	3
203	GC0601	FUSE, 2AMP	1
204	15W684	MODULE, HEATER CONTROL, GUARDIAN	2
205*		RAIL, DIN; 0.875	
208	GC0859	FUSE, FUSEHOLDER, DIN RAIL	4
209	GC0956	LABEL, EMERGENCY STOP	1
210	GC0972	BLOCK, JUMPER, TERMINAL	2
212	GC1161	RELAY, 3 POLE 10AMP	4
213	GC1164	SOCKET, RELAY, 3 POLE, 10AMP	4
214	GC1172	TERMINAL, 2IN/2OUT	6
215	GC1173	COVER, END, TERMINAL, 2 in., 2 OUT	3
217	GC1608	BUTTON, LATCHED	2
218	GC1609	BUTTON, MOMENTARY	3
219	GC1611	BUTTON, EMERGENCY STOP	1
220	GC1612	PLATE, COUPLING	6

Ref.	Part	Description	Qty.
221	GC1614	LENS, ILLUMINATED, "R"	3
222	GC1616	LENS, ILLUMINATED, "I/O"	2
223	GC1617	LENS, YELLOW	3
224	GC1619	LENS, GREEN	2
225	GC1622	LED, YELLOW, 24V	3
226	GC1624	LED, GREEN, 24V	2
227	GC1626	BLOCK, CONTACT, NORMALLY OPEN	5
228	GC1627	BLOCK, CONTACT, NORMALLY CLOSE	5
230	GC1779	CABLE, PLUG, ELEC., FEMALE	2
231	GC1780	CABLE, PLUG, ELEC., FEMALE	1
232	GC1782	CABLE, PLUG, ELECTRICAL, MALE, 6, SM	2
233	GC1783	CABLE, PLUG, ELECTRICAL, MALE	1
236	15W687	MODULE, HOSE CONTROL, GUARDIAN	1

\* Source locally.

## Section 3 - General Information: Sub Assembly Drawings

### GC1768 Electrical Assembly

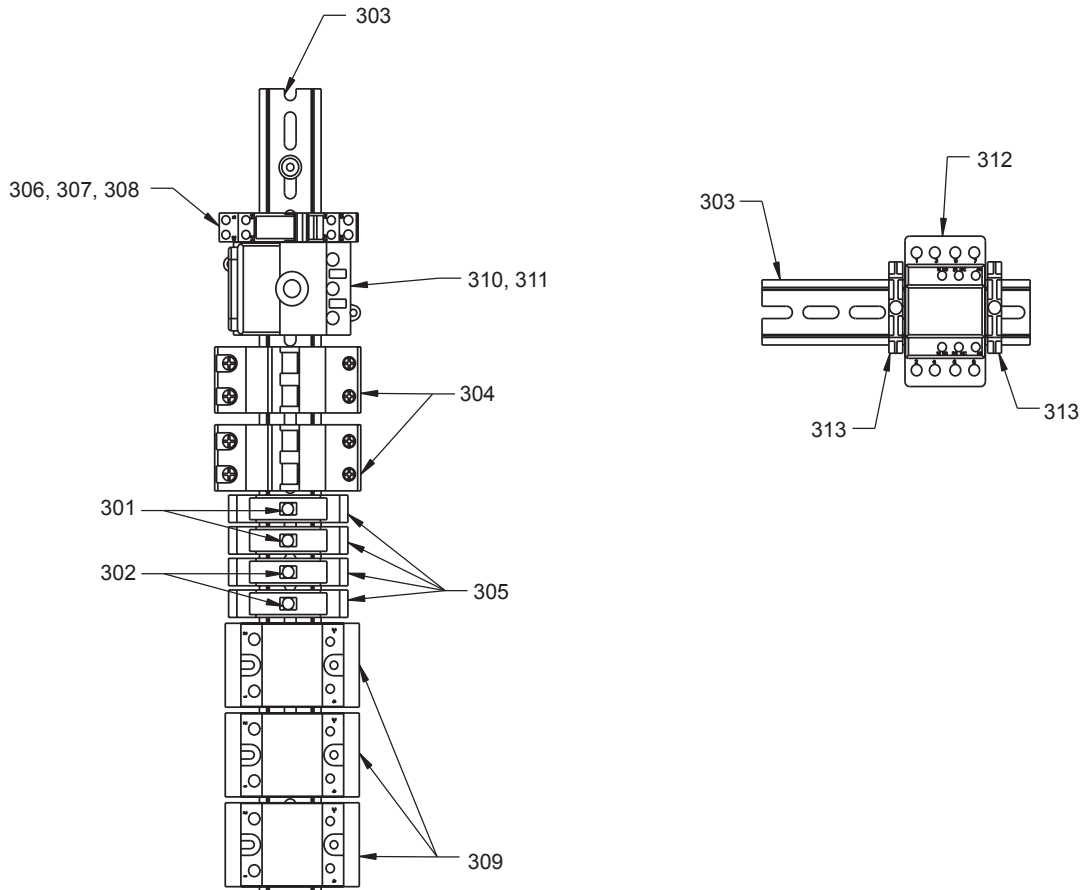

Ref.	Part	Description	Qty.
301	GC0601	FUSE, 2 AMP	2
302	GC0602	FUSE, 3AMP	2
303*		RAIL, DIN	1
304	GC0853	CIRCUIT BRKR, CIRCUIT, DIN RAIL, 20/2	2
305	GC0859	FUSE, FUSEHOLDER, DIN RAIL	4
306	GC0863	RELAY, FINDER, DIN RAIL, 16A	1
307	GC0864	RELAY, SOCKET, DIN RAIL W/OUTCLI	1
308	GC0866	CLIP, RELAY, SOCKET, DIN RAIL	1
309	GC1015	RELAY, SOLID STATE, 50A	3
310	GC1057	SWITCH, SWITCH, ON/OFF, 3 POLES	1
311	GC1062	COVER, BLOCK, SWITCH, ON/OFF, 3POL	1
312	GC1262	RELAY, CONTCTR, MECHANICAL, 4-POLE	1
313	GC1651	CLAMP, END, TERMINAL, UNIVERSAL	2

\* Source locally.

## Section 3 - General Information: Sub Assembly Drawings

### GC1769 Electrical Assembly

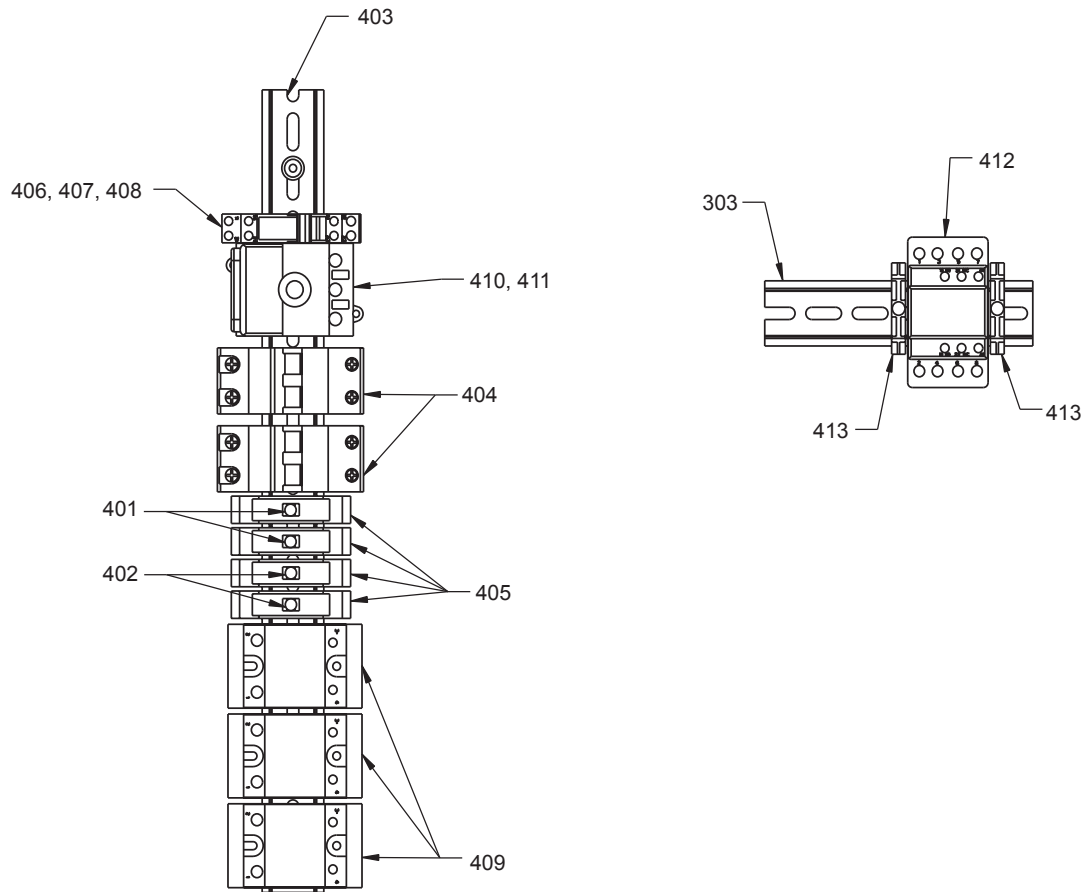

Ref.	Part	Description	Qty.
401	GC0601	FUSE, 2 AMP	2
402	GC0602	FUSE, 3AMP	2
403*		RAIL, DIN	1
404	GC0853	CIRCUIT BRKR, CIRCUIT, DIN RAIL, 20/2	2
405	GC0859	FUSE, FUSEHOLDER, DIN RAIL	4
406	GC0863	RELAY, FINDER, DIN RAIL, 16A	1
407	GC0864	RELAY, SOCKET, DIN RAIL W/OUTCLI	1
408	GC0866	CLIP, RELAY, SOCKET, DIN RAIL	1
409	GC1015	RELAY, SOLID STATE, 50A	3
410	GC1055	SWITCH, SWITCH, ON/OFF, 3 POLES	1
411	GC1060	COVER, BLOCK, SWITCH, ON/OFF, 3POL	1
412	GC1262	RELAY, CONTCTR, MECHANICAL, 4-POLE	1
413	GC1651	CLAMP, END, TERMINAL, UNIVERSAL	2

## Section 3 - General Information: Sub Assembly Drawings

### GC1786 ISO / GC1787 POLY Heat Exchanger Assembly

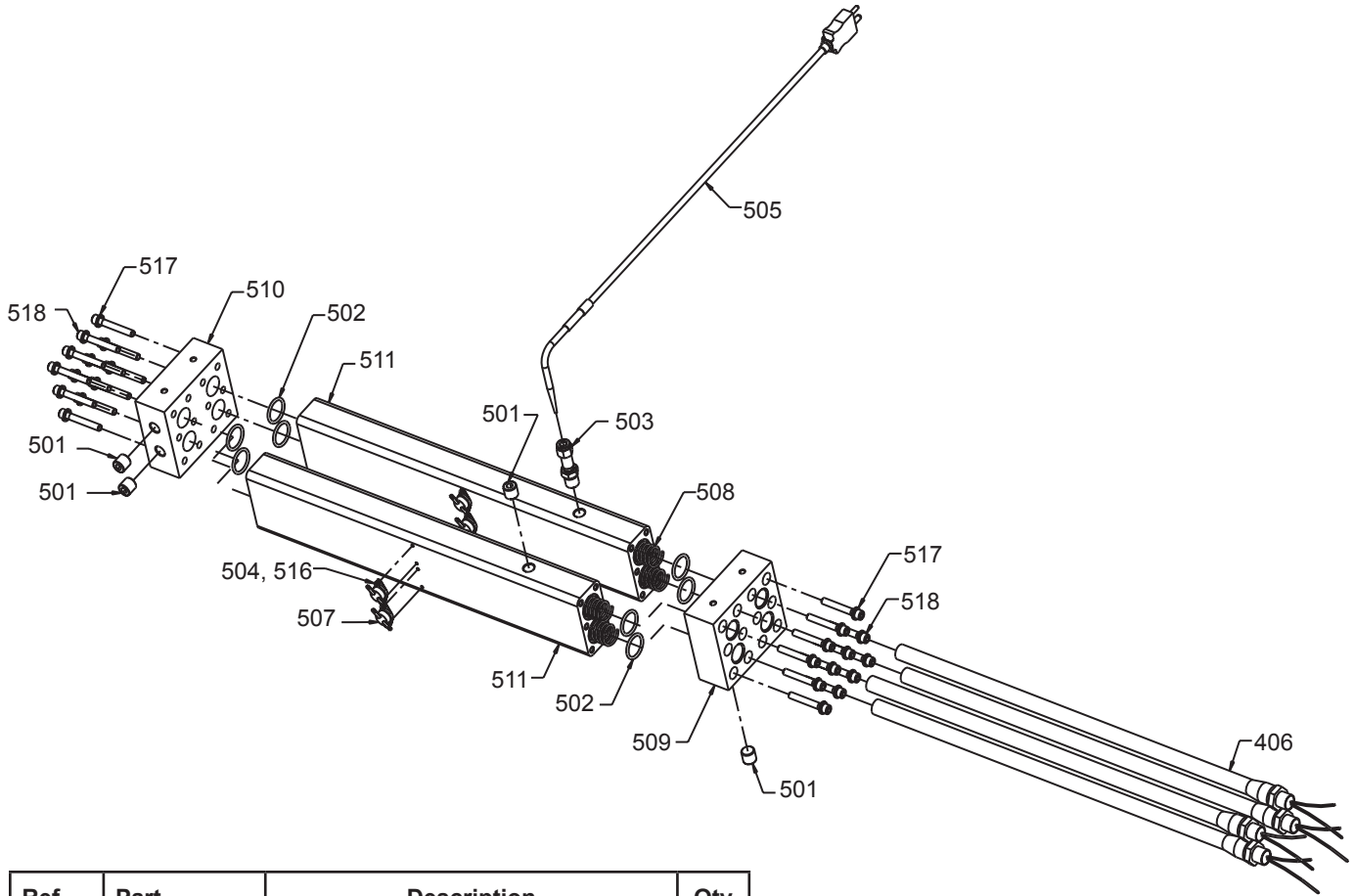

Ref.	Part	Description	Qty.
501	GC0025	PLUG, PIPE	1
502	GC1748	KIT, O-RING (kit includes 4)	8
503	GC0482	CONNECTOR	1
504	GC0554	SCREW	8
505	GC0559	THERMOCOUPLE, VELOCITY, HIGH	1
506	GC0891	ELEMENT, HEATER, 1500 W	4
507	GC0962	SWITCH, OVERTEMP	4
508	GC1226	SPRING, COMPRESSION,	4
509	GC1784	CAP, FRONT, HEATER, 4 ROD	1
510	GC1785	CAP, REAR, HEATER, 4 ROD	1
511	GC1713	HOUSING, BODY, EXTRUDED, HEATER	2
512	GC1773	CABLE, PLUG, ELEC., FEMALE	1
513†	GC1774	CABLE, PLUG, ELEC., MALE	1
514†	GC1778	CABLE, PLUG, ELEC., FEMALE	1
515†	GC1781	CABLE, PLUG, ELEC., MALE	1
516†	GC2105	WASHER, LOCK, SPRING	8
517	GC2109	WASHER, LOCK, SPRING	24
518	GC2151	SCREW	24

† Not shown.

## Section 3 - General Information: Maintenance

### Daily Routine Maintenance

1. Visually inspect the system for leaks.
2. Check desiccant dryer ensure proper functioning.  
Replace dryer beads as necessary.
3. Check and lube top of the fluid section.

Wipe off residual material  
and add a tablespoon  
of throat seal liquid (TSL).

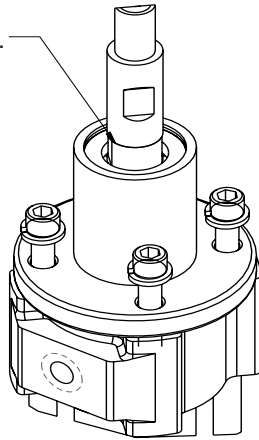

### Weekly Maintenance

1. Place a small amount of grease on the air motor shaft.
2. See related manuals.

## Section 3 - General Information: Troubleshooting



*Do not place any part of the body in the path of the material spray.*

*Do not point the gun at or near other personnel.*

*Do not look into the Mixing Chamber orifice at any time.*

*Because of the hazardous materials used in this equipment, it is recommended that the operator use an air mask, goggles, protective clothing, and other safety equipment as prescribed by current regulations, recommendations of the chemical suppliers, and the laws in the area where the equipment is being used.*

The system will dispense liquid at high pressure when Gun Trigger is activated. Read and note WARNINGS contained in this User Manual and the Probler P2 Gun User Manual, GC-1386.



*The Polyol will expand in the Hose if any normal operating pressures are bled off whenever the material is above approximately 75 degrees F. Hot Polyol hoses should never be bled, by any method, to zero pressure for two reasons.*

*1. The seals in the Gun rely on high pressure to make their seal. The high pressure cannot be maintained if the pumps are attempting to apply this pressure through a hose full of expanded froth; therefore, the Gun seal may leak.*

*2. Re-starting immediately after hot Polyol has expanded in the system may result in spraying substantial amounts of "bad" foam. This will continue until the expanded Polyol in the primary Heater and the Hose has been completely purged.*

### Over Pressure System Protection

The system incorporates monitors for high pressure monitoring. These monitoring devices will prevent the system from continued operation if high pressure situations develop.

There are pressure sensors located on each proportioning pump. The high pressure sensor is located at the outbound of the fluid section.

The high pressure monitoring sensor will engage if fluid pressure increases above 3000 psi.

If a high pressure situation develops, the sensor will detect this and immediately engage the hold-in circuit.

This will disengage power to the air motor and will also turn the heaters off.

On the control box panel, there are three yellow lighted push buttons marked over pressure. One of these push buttons will be illuminated after the monitoring sensor engages, indicating where the problem is located (ISO, Poly, or Hose).

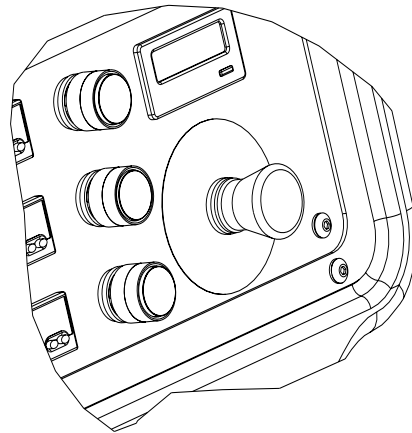

In the over pressure situation, the system will remain shut-down until it is manually reset.

At this point, it is necessary to determine if the problem is an over pressure situation.

When the sensor engages, the system will be frozen, giving you the pressure readings at the time the problem was detected.

Inspect the fluid pressure gauges, in an over pressure situation, one of the fluid pressure gauges will be significantly higher than the other gauge.



*When main power to unit is on, the console will have wires that are live. Disconnect or turn off main power source before opening console to make any repairs.*



*Before performing any repairs on the system, ALL AIR and FLUID PRESSURES SHOULD BE RELIEVED TO ZERO (BLEED-OFF)!*

## Section 3 - General Information: Troubleshooting

### Over Pressure Problem Correction

1. Determine if the problem is high pressure related.
2. Relieve system material pressure.
3. Turn off main power.
4. Fix the problem area:
  - a. Potential high pressure causes:
    - Restriction
    - Overheating material in static position
    - ISO filter at gun
5. Re-start system for operation

 Once the power has been turned off and problem solved, and the main power is turned on again, the over pressure lighted buttons will automatically be reset.



If you do not understand the electrical hook-up described above, consult your local GlasCraft distributor OR a qualified electrician.

It is recommended that a qualified, licensed electrician should install power to the supply disconnect.

You should always follow all local or national electrical codes.



Disconnect power source BEFORE attempting any repairs or opening the Control Boxes. Access to internal parts is limited to qualified personnel ONLY! Place Main Power Switch in OFF position BEFORE disconnecting power cables. This equipment is not approved for use in hazardous locations as set forth in the National Electrical Code Article 500 and Sub-Part "S" of the OSHA Standards.

### Material Or Mechanical Problem

#### Troubleshooting Procedure

By following this procedure, you should be able to locate and cure problems easily. Remember, however, that a successful operator must know:

- WHAT GOOD MATERIAL LOOKS LIKE.
- HOW THE EQUIPMENT NORMALLY OPERATES.
- WHAT PATH THE MATERIALS FOLLOW THROUGH THE EQUIPMENT.
- KNOWLEDGE OF THESE TROUBLESHOOTING PROCEDURES.



Always start with step one, never skip any portion of these procedures. The material pressure gauges are to be used for troubleshooting purposes only. The pressures registered on one gauge will not necessarily match the other. This difference can be caused by variance in materials, temperatures, viscosities, etc.

1. Identify the missing material.
2. Check the material pressure gauge on the missing material side.
  - a. If the missing material gauge reads HIGHER than normal, there is a RESTRICTION problem between the gauge and the Mixing Chamber tip in the Gun.
  - b. If the missing material gauge reads LOWER than normal, there is a STARVATION problem between the gauge and the material supply system.



Problems may be cyclic in that they will appear first on only one stroke of the Proportioning Pump. Check the pressure gauges during one of these bursts of missing materials and always stop spraying while you are getting a burst of good material.

3. Concern yourself only with the material pressure on the missing material side. In troubleshooting a STARVATION problem where the pressure gauge on the missing material side is LOWER than normal, start at the point farthest from the unit and work forward. Check the obvious and easy things first.



## Section 3 - General Information: Troubleshooting

### A. MATERIAL DRUMS

1. Material in drums?
2. Material temperature?
  - a. If the material is too cold, especially at the bottom of the drum, it will raise the viscosity of the material and stall Transfer Pumps.

### B. OPTIONAL TRANSFER PUMP(S)

1. Is it operating?
2. Is air turned on to Transfer Pump?
3. Regulated pressure where it should be?
4. Severe contamination of pump shaft on isocyanate side. This indicates that the pump shaft is not being lubricated.
5. Check Filter of Transfer Pump.
6. Before diagnosing a faulty Transfer Pump, be sure and check all items just listed under Transfer Pump.

### C. FILTER ASSEMBLY

1. Check fluid filter at inlet to Proportioning Pumps if applicable.

### D. PROPORTIONING PUMPS

1. Determine whether the burst appears on the Pump's up or down stroke.
  - a. If burst appears on UP stroke, check UPPER Ball Seat and Cups.
  - b. If burst appears on DOWN stroke, check LOWER Ball Seat

 Follow the procedures in the order given. Remember that repairs should be made as soon as possible. Don't leave the unit open to air any longer than necessary, as this will lead to further problems, such as moisture entering the system and causing the isocyanate to crystallize.

After the unit has been exposed to the atmosphere, it should be run long enough to displace the material that was in the unit when it was opened up.

**NEVER inspect filter assemblies at time of shut-down!**

4. In troubleshooting, a restriction problem where the material pressure gauge on the missing material side is higher than normal, start at the point farthest from the unit and work backward. Check obvious and easy things first.



Before performing any repairs on the Gun, ALL AIR and FLUID PRESSURES SHOULD BE RELIEVED TO ZERO (BLEED-OFF)!

### A. GUN

1. Side Block Material Valve turned on?
2. Bore hole of Mixing Chamber clean?
3. Filter Strainer Screen clean?
4. Side hole in Mixing Chamber clean?

### B. MATERIAL TEMPERATURE

1. Too high a temperature on resin side can cause a blowing agent to pre-expand in either the Hose or the Primary Heater.

### C. HOSES

1. Make sure that the Hoses are not plugged.

### TROUBLESHOOTING A POOR SPRAY PATTERN

 To troubleshoot a poor spray pattern, you must understand the factors that affect the spray pattern.

### A. TEMPERATURE

1. Too warm a material temperature will cause a separation (fingering) in the pattern.
2. Too cold a material temperature will cause a stream effect.

### B. PRESSURE

1. Too high a pressure will cause excessive overspray and/or separation (fingering).
2. Too low a pressure will cause a stream effect.

### C. CONTAMINATION IN THE MIXING CHAMBER

1. A foreign object in the Mixing Chamber will cause a poor pattern.

 Correct problem(s) immediately!

## Section 3 - General Information: Options

### GC0174 Transfer Kit (Supplied with Unit)

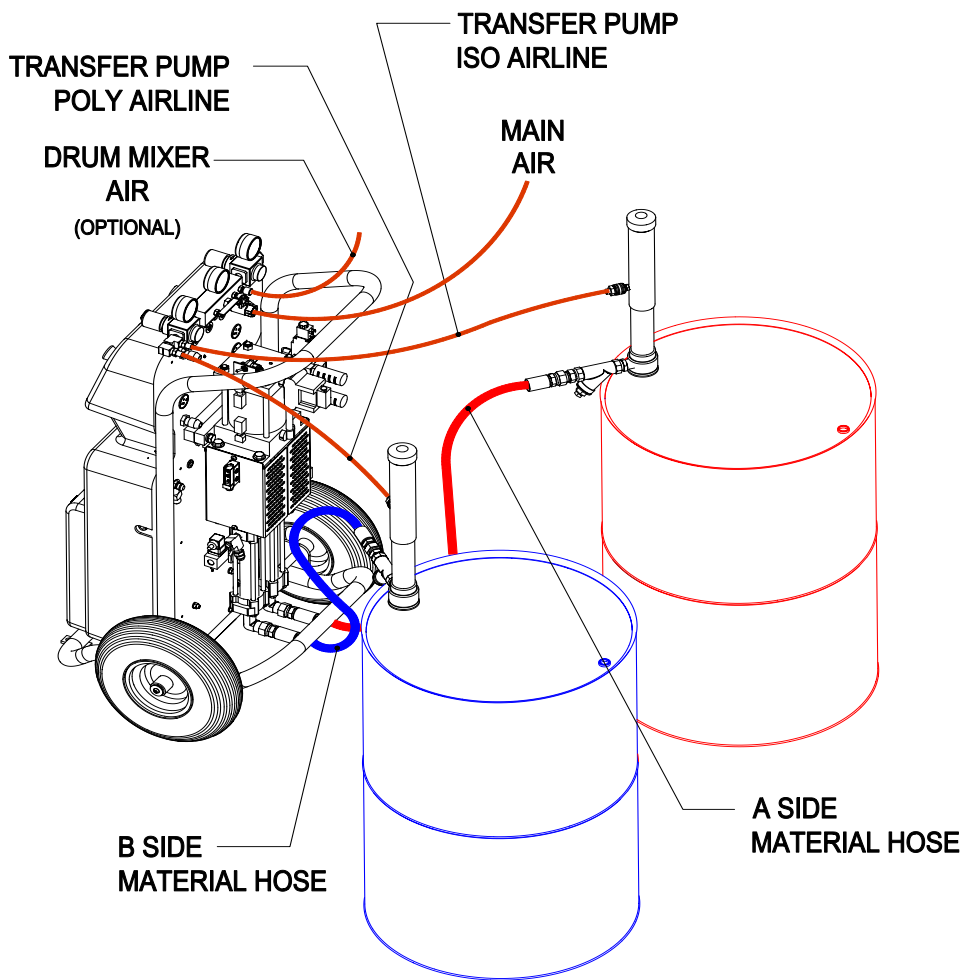
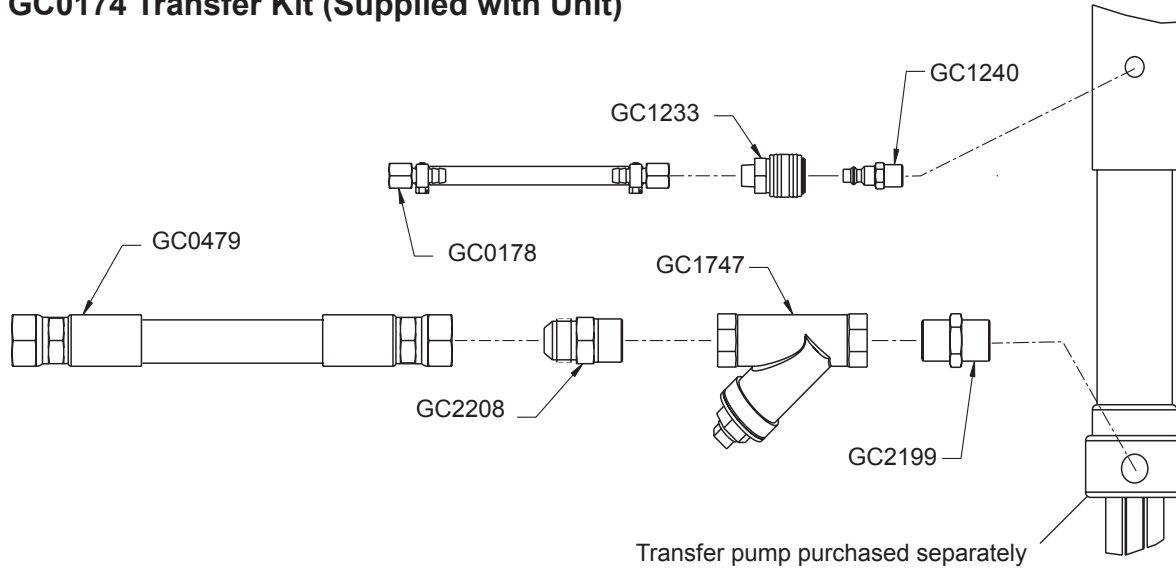

The transfer kit attaches the same way for both ISO & POLY side. Use PTFE tape on NPT threads.





## Section 4 - Safety Information: Limited Warranty Policy

### Graco Standard Warranty

Graco warrants all equipment referenced in this document which is manufactured by Graco and bearing its name to be free from defects in material and workmanship on the date of sale to the original purchaser for use. With the exception of any special, extended, or limited warranty published by Graco, Graco will, for a period of twelve months from the date of sale, repair or replace any part of the equipment determined by Graco to be defective. This warranty applies only when the equipment is installed, operated and maintained in accordance with Graco's written recommendations.

This warranty does not cover, and Graco shall not be liable for general wear and tear, or any malfunction, damage or wear caused by faulty installation, misapplication, abrasion, corrosion, inadequate or improper maintenance, negligence, accident, tampering, or substitution of non-Graco component parts. Nor shall Graco be liable for malfunction, damage or wear caused by the incompatibility of Graco equipment with structures, accessories, equipment or materials not supplied by Graco, or the improper design, manufacture, installation, operation or maintenance of structures, accessories, equipment or materials not supplied by Graco.

This warranty is conditioned upon the prepaid return of the equipment claimed to be defective to an authorized Graco distributor for verification of the claimed defect. If the claimed defect is verified, Graco will repair or replace free of charge any defective parts. The equipment will be returned to the original purchaser transportation prepaid. If inspection of the equipment does not disclose any defect in material or workmanship, repairs will be made at a reasonable charge, which charges may include the costs of parts, labor, and transportation.

THIS WARRANTY IS EXCLUSIVE, AND IS IN LIEU OF ANY OTHER WARRANTIES, EXPRESS OR IMPLIED, INCLUDING BUT NOT LIMITED TO WARRANTY OF MERCHANTABILITY OR WARRANTY OF FITNESS FOR A PARTICULAR PURPOSE.

Graco's sole obligation and buyer's sole remedy for any breach of warranty shall be as set forth above. The buyer agrees that no other remedy (including, but not limited to, incidental or consequential damages for lost profits, lost sales, injury to person or property, or any other incidental or consequential loss) shall be available. Any action for breach of warranty must be brought within two (2) years of the date of sale.

GRACO MAKES NO WARRANTY, AND DISCLAIMS ALL IMPLIED WARRANTIES OF MERCHANTABILITY AND FITNESS FOR A PARTICULAR PURPOSE, IN CONNECTION WITH ACCESSORIES, EQUIPMENT, MATERIALS OR COMPONENTS SOLD BUT NOT MANUFACTURED BY GRACO. These items sold, but not manufactured by Graco (such as electric motors, switches, hose, etc.), are subject to the warranty, if any, of their manufacturer. Graco will provide purchaser with reasonable assistance in making any claim for breach of these warranties.

In no event will Graco be liable for indirect, incidental, special or consequential damages resulting from Graco supplying equipment hereunder, or the furnishing, performance, or use of any products or other goods sold hereto, whether due to a breach of contract, breach of warranty, the negligence of Graco, or otherwise.

#### **FOR GRACO CANADA CUSTOMERS**

The Parties acknowledge that they have required that the present document, as well as all documents, notices and legal proceedings entered into, given or instituted pursuant hereto or relating directly or indirectly hereto, be drawn up in English. Les parties reconnaissent avoir convenu que la rédaction du présente document sera en Anglais, ainsi que tous documents, avis et procédures judiciaires exécutés, donnés ou intentés, à la suite de ou en rapport, directement ou indirectement, avec les procédures concernées.

### Graco Information

**TO PLACE AN ORDER**, contact your Graco distributor or call to identify the nearest distributor.

Phone: 612-623-6921 or Toll Free: 1-800-328-0211 Fax: 612-378-3505

**PARA EFETUAR ENCOMENDAS OU PARA ASSISTÊNCIA TÉCNICA**, contate o seu distribuidor da Graco.

**POUR PLACER UNE COMMANDE OU DEMANDER DU SERVICE**, contactez votre distributeur Graco.

**PARA REMITIR UN PEDIDO O SOLICITAR SERVICIO**, póngase en contacto con el distribuidor de Graco.

## Section 4 - Safety Information: Technical Assistance.....

### **Thank You for selecting GlasCraft spray equipment**

Should you have any questions or need technical assistance, contact your factory authorized GlasCraft distributor.

Distributor: \_\_\_\_\_

Phone: \_\_\_\_\_

Contact: \_\_\_\_\_



For any issues your distributor cannot address, the GlasCraft technical service department is always available to assist you with the operation of your spray equipment. To help our technical representatives expedite your call and better address your questions, please have the following information ready and available when you phone GlasCraft.

**\* If your questions are not urgent, You can e-mail all correspondence to [service@glascraft.com](mailto:service@glascraft.com)**

Model: \_\_\_\_\_

Serial number: \_\_\_\_\_

Type of spray gun: \_\_\_\_\_

Serial number: \_\_\_\_\_

Is your equipment:

Single phase: \_\_\_\_\_ Three phase \_\_\_\_\_

What is the inbound voltage to your equipment: \_\_\_\_\_

Temperature setting ISO: \_\_\_\_\_

Temperature setting POLY: \_\_\_\_\_

Temperature setting HOSE: \_\_\_\_\_

### **For Air Powered Systems:**

Air compressor size: \_\_\_\_\_

CFM generated: \_\_\_\_\_

Pressure at the system:

Hydraulic \_\_\_\_\_ Pneumatic \_\_\_\_\_

Dynamic fluid pressure:

ISO \_\_\_\_\_ POLY \_\_\_\_\_

Spray gun chamber size: \_\_\_\_\_

Material being sprayed: \_\_\_\_\_

Viscosity: ISO \_\_\_\_\_ POLY \_\_\_\_\_

Approximate material temperature: \_\_\_\_\_

For Your Reference



**Date Purchased** \_\_\_\_\_  
**Distributor** \_\_\_\_\_  
\_\_\_\_\_  
**Contact** \_\_\_\_\_  
**Phone** \_\_\_\_\_  
**E-mail** \_\_\_\_\_

GlasCraft manufactures a complete line of polyurethane foam and polyurea coating spray systems. If your application is in-plant or a field contractor - GlasCraft has a system package to meet your requirements.

***GUARDIAN - AIR POWERED / A5 & A6 SERIES EQUIPMENT***

- . 6000 OR 12000 WATTS OF HEAT
- . 1600, 2200, OR 3000 PRESSURE SET-UPS AVAILABLE

***MH, MH II, & MH III HYDRAULIC POWERED SYSTEMS***

- . UP TO 45 LBS / MINUTE OUTPUT
- . EXCELLENT PERFORMANCE AND RELIABILITY

***GUARDIAN MMH - MOBILE MODULAR HYDRAULIC SYSTEMS***

- . SPECIFICALLY DESIGNED FOR ANY TYPE OF SPRAY RIG
- . GIVE COMPLETE UTILIZATION OF FLOOR SPACE IN MOBILE RIG

***PROBLER P2 SPRAY GUN***

- . IMPINGEMENT MIX / AIR PURGE
- . OPTIONAL NOZZLE FOR SPRAYING STUD WALLS, POURING & STREAM JET

For more information concerning any of these GlasCraft products, contact your local authorized GlasCraft distributor or visit [www.glascraft.com](http://www.glascraft.com)



Quality and Performance...  
GENUINE GLASCRAFT

**Glas** **Craft**

DISPENSING EXCELLENCE

**ADS**  
ADVANCED DISPENSE  
SYSTEMS

[www.glascraft.com](http://www.glascraft.com)

313275B

GRACO INC.  
P.O. BOX 1441  
MINNEAPOLIS, MN 55440-1441

Phone 612-623-6921  
Toll Free 1-800-328-0211  
Fax 612-378-3505